

Service Manual

FM Quartz Locked
STEREO RECEIVER

SX-3800

Bulletin SI-A35015 ^{correction} change of output
Q1 to 2SC2525 DOME on schematic.

 PIONEER®

MODEL SX-3800 COMES IN FOUR VERSIONS DISTINGUISHED AS FOLLOWS:

Type	Voltage	Remarks
KU	120V only	U.S.A. model
S/G	110V, 120V, 220V, and 240V (Switchable)	U.S. Military model
S	110V, 120V, 220V, and 240V (Switchable)	General export model
KC	120V only	Canada model

- This service manual is applicable to the KU type. When repairing the S/G and S type, please see the additional service manual (p 47 -p57). When repairing the KC type, please see the additional service manual (ART-519).

CONTENTS

1. SPECIFICATIONS	3	8.2 AM Tuner	22
2. FRONT PANEL FACILITIES	5	8.3 Power Amplifier	23
3. BLOCK DIAGRAM	7	8.4 FL Indicator Circuit	24
4. CIRCUIT DESCRIPTIONS		9. EXPLODED VIEW	25
4.1 FM Tuner	8	10. SCHEMATIC DIAGRAM, P.C. BOARD CONNECTION DIAGRAM AND PARTS LIST	
4.2 AM Tuner	9	10.1 Schematic Diagram	31
4.3 Display Circuit	9	10.2 P.C. Board Connection Diagram	35
4.4 Equalizer Amplifier	12	10.3 Parts List	41
4.5 Tone Control Amplifier	12	11. PACKING	46
4.6 Power Amplifier	12	ADDITIONAL SERVICE MANUAL	
4.7 Power Indicator Circuit	14	1. SPECIFICATIONS	47
4.8 Protection Circuit	14	2. CONTRAST OF MISCELLANEOUS PARTS	48
5. DISASSEMBLY	16	3. SCHEMATIC DIAGRAM, P.C. BOARD PATTERNS AND PARTS LIST	
6. PARTS LOCATION	17	3.1 Schematic Diagram	49
7. DIAL CORD STRINGING	19	3.2 Switch Assembly (AWS-148)	57
8. ADJUSTMENTS			
8.1 FM Tuner	20		

1. SPECIFICATIONS

Power Amplifier Section

Continuous Power Output of 60watts* per channel, min., at 8 ohms from 20Hertz to 20,000 Hertz with no more than 0.005% total harmonic distortion.

Total Harmonic Distortion (20 Hertz to 20,000 Hertz, 8 ohms)

continuous rated power output . . . No more than 0.005%
30 watts per channel power output

..... No more than 0.005%

Intermodulation Distortion (50 Hertz : 7,000 Hertz = 4 : 1)

continuous rated power output . . . No more than 0.005%
30 watts per channel power output

..... No more than 0.005%

Frequency Response

..... 5 Hertz to 200,000 Hertz $^{+0}_{-3}$ dB

Input Sensitivity/Impedance (POWER AMP IN)

..... 1V/50 kilohms

Output

Speaker A, B, A+B

Damping Factor (20 Hertz to 20,000 Hertz, 8 ohms)

..... 50

Hum and Noise (IHF, short-circuited, A network)

..... 115dB

Preamplifier Section

Input (Sensitivity/Impedance)

PHONO 2.5mV/50 kilohms

AUX, TAPE PLAY 1, 2 150mV/50 kilohms

Phono Overload Level (T.H.D. 0.005%, 1,000 Hertz)

PHONO 250mV

Output (Level/Impedance)

TAPE REC 1, 2 150mV

PREAMP OUT (R_L: 50 kilohms)

..... 1V/1 kilohms (Volume: max.)

Total Harmonic Distortion (20 Hertz to 20,000 Hertz)

PHONO (REC OUT) No more than 0.005%
(10V output)

AUX, TAPE PLAY 1, 2 No more than 0.005%
(10V output)

Frequency Response

PHONO (RIAA Equalization)

..... 20 Hertz to 20,000 Hertz ± 0.2 dB

AUX, TAPE PLAY 1, 2

..... 7Hz to 80,000 Hertz $^{+0}_{-1}$ dB

Tone Control

BASS ± 8 dB (100Hz)

TREBLE ± 10 dB (10,000Hz)

Subsonic Filter 15Hz (-6dB/oct.)

Loudness Contour (Volume control set at -40dB position)

..... +6dB (100Hz), +3dB (10,000Hz)

Hum and Noise (IHF, short-circuited, A network)

PHONO 82dB

AUX, TAPE PLAY 1, 2 110dB

Attenuator -20dB

FM Tuner Section

Usable Sensitivity (IHF) 10.3dBf (1.8 μ V)

50dB Quieting Sensitivity

MONO 16.2dBf (3.6 μ V)

STEREO 37dBf (39 μ V)

Signal-to-Noise Ratio

MONO 83dB (at 65dBf)

STEREO 78dB (at 80dBf)

Distortion (at 65dBf)

MONO 100Hz 0.1%

1kHz 0.07%

6kHz 0.15%

STEREO 100Hz 0.2%

1kHz 0.15%

6kHz 0.25%

Capture Ratio 1.0dB

Alternate Channel Selectivity

400kHz 75dB

Stereo Separation

1kHz 45dB

30Hz to 15kHz 35dB

Frequency Response

..... 20Hz to 15kHz $^{+0.2}_{-1.2}$ dB

Spurious Response Ratio 65dB

Image Response Ratio 65dB

IF Response Ratio 90dB

AM Suppression Ratio 55dB

Subcarrier Product Ratio 50dB

SCA Rejection Ratio 64dB

Muting Threshold 19.2dBf (5 μ V)

Antenna Input 300 ohms balanced,

75 ohms unbalanced.

AM Tuner Section

Sensitivity (IHF, Ferrite antenna) . . .	300 μ V/m
(IHF, Ext. antenna) . . .	15 μ V
Selectivity	30dB
Signal-to-Noise Ratio	50dB
Image Response Ratio	40dB
IF Response Ratio	40dB
Antenna	Ferrite loopstick antenna

Audio Section

Output (Level/Impedance)	
FM (100% Mod.)	650mV/1 kilohms
AM (30% Mod.)	200mV/1 kilohms

Semiconductors

ICs	17
FETs	6
Transistors	71
Diodes	58

Miscellaneous

Power Requirements	AC 120V, 60Hz
Power Consumption	200W (UL)
Dimensions	506(W) x 164(H) x
	434(D) mm
	19-15/16(W) x 6-7/16
	(H) x 17-1/16(D) in
Weight (without package)	16.2kg (35lb 12oz)

Furnished Parts

Operating instructions	1
FM T-type antenna	1

** Measured pursuant to the Federal Trade Commission's Trade Regulation rule on Power Output Claims for Amplifiers.*

NOTE:

Specifications and the design subject to possible modifications without notice due to improvements.

2. FRONT PANEL FACILITIES

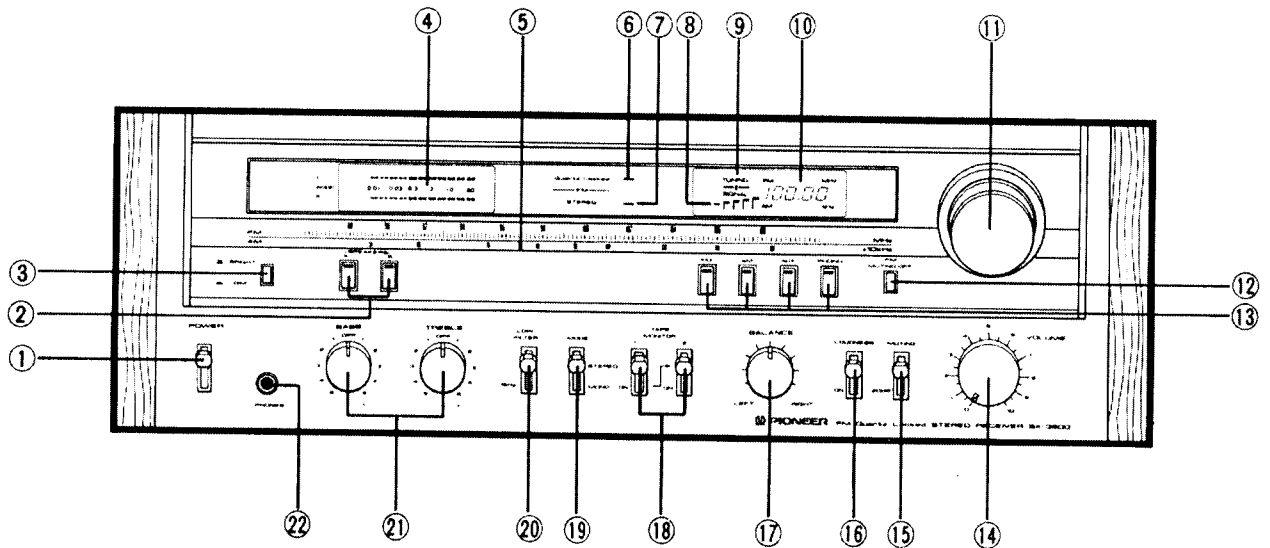

① POWER SWITCH

Set this switch to ON to supply power to the receiver. There will be a short delay when it is set to ON, because the muting circuit has been actuated to suppress the unpleasant noise that is sometimes generated when the power is switched on and off.

② SPEAKER SWITCHES

Depress the switch corresponding to the speakers connected to the SPEAKERS terminals (A or B) on the rear panel.

You can depress both of these buttons to listen to the sound from two pairs of speaker systems at the same time.

③ BRIGHTNESS SELECTOR

Use this switch to select the brightness of the power meter and the frequency display.

BRIGHT: When using the receiver in daylight or other bright locations.

DIM: At night or in dark locations when the existing brightness is too high.

④ POWER METER

This meter allows you to read out the rated power level on the fluorescent display tube when speakers with a nominal impedance of 8 ohms are connected to the speaker terminals.

⑤ DIAL POINTER

This pointer indicates the broadcasting stations.

⑥ QUARTZ LOCKED INDICATOR

This indicator lights up after the optimum tuning point has been obtained and displays that the receiving state is stabilized by the built-in quartz lock circuit.

⑦ FM STEREO INDICATOR

This indicator lights up when receiving an FM stereo program if the FM muting off switch is released.

⑧ SIGNAL INDICATOR

This indicator lights in sequence from left through right during the tuning of an AM or FM broadcast in accordance with the strength of the signals being received. The optimum tuning point is where the maximum number of indicators light.

⑨ TUNING INDICATOR

When tuning in an FM station, the optimum reception point is indicated when the center indicator lights up. When the left indicator has come on, rotate the tuning knob slightly clockwise. When the right indicator comes on, rotate the knob slightly counterclockwise.

⑩ FREQUENCY DISPLAY

This indicates the frequency which is tuned.

With FM reception, the letters "FM" appear on the left of the display and "MHz" on the right. With AM reception, "AM" appears on the left and "kHz" on the right. These change when the function selector position is changed.

⑪ TUNING KNOB

Use this knob to tune in to broadcasting stations.

⑫ FM MUTING OFF SWITCH

When this switch is released and an FM broadcast tuned in, the muting circuit is activated inside to suppress the annoying interstation noise between the broadcasting frequencies for noise-free reception. When the broadcasting station is far away or when receiving a station in a fringe area, set the switch to the OFF position and then tune in. If there is a broadcasting station with a strong

signal level on the air next to a station whose program you want to receive, you may not be able to tune in satisfactorily because the sound will be drowned out by the stronger signals. In cases like this, set the FM MUTING OFF switch to OFF (depressed position) and tune in. The muting circuit does not work when the tuner is receiving AM broadcasts. If tuning has been performed after the FM MUTING OFF switch has been depressed and a station selected, the quartz locked circuit is set to the OFF mode and the LOCKED indicator does not light.

⑬ FUNCTION SELECTOR

Depress the function switch which corresponds to the program source. Turn the volume control down first before selecting a different function switch while the sound from one program source is being reproduced.

FM: Depress this switch for FM broadcasts.

AM: Depress this switch for AM broadcasts.

AUX: Depress this switch when listening to an audio component connected to the AUX jacks.

PHONO: Depress this switch when playing a record on the turntable connected to the PHONO jacks.

NOTE:

Only one function switch should be depressed at a time.

⑭ VOLUME CONTROL

Use this control to adjust the output level to the speakers and headphones. Turn it clockwise to increase the output level. No sound will be heard if you set it to "0."

⑮ MUTING SWITCH

Set this switch to the -20dB position to attenuate the audio output by 20dB. There is no need to adjust the volume control if you this switch when turning down the audio output temporarily and when changing over records or tapes.

⑯ LOUDNESS SWITCH

When listening to a performance with the volume control turned down, depress this switch and the bass and treble will be accentuated.

When the volume is low, the human ear finds it harder to hear the bass and treble than when the volume is high. The loudness switch is thus designed to compensate for this deficiency. By depressing this switch, the bass and treble come through much more strongly and the sound takes on a punch even when the volume control is turned down,

⑰ BALANCE CONTROL

Use this control to balance the volume of the left and right channels. First, however, set the mode switch to

MONO. If the sound appears to be louder on the right, it means that the volume of the right channel is higher. Turn the balance control to the left and adjust. Conversely, if the sound appears to be louder on the left, it means that the volume of the left channel is higher. Therefore, turn the balance control to the right and adjust. After adjusting, return the mode switch to STEREO.

⑱ TAPE MONITOR SWITCHES

Employ for tape playback or to monitor a recording in progress.

1: Playback or monitoring of a tape deck connected to the TAPE 1 jacks.

2: Playback or monitoring of a tape deck connected to the TAPE 2 jacks.

NOTES:

1. *Be sure to set the switches to the upper (OFF) position when playing records or listening to broadcasts.*

2. *When recording with two tape decks simultaneously, do not operate the tape monitor 1 switch as this will interrupt the signal to the TAPE 2 deck.*

⑲ MODE SWITCH

Use this switch for selecting mono or stereo performances.

STEREO: Set to this position for normal operations.

MONO: When set to this position, the left and right channel signals will be mixed and reproduced monophonically from both speaker systems.

⑳ LOW FILTER SWITCH

When this switch is set to 15Hz, a 6dB/oct attenuation can be provided for frequencies below 15Hz. This means that you can cancel out noise in the ultra-low frequencies which is generated by low-pitched rumble from a turntable and other forms of distortion. Although this noise cannot be heard, it can generate intermodulation distortion and damage the speakers.

㉑ BASS AND TREBLE CONTROLS

When turned clockwise from the OFF position, the response in the bass and treble range, respectively, is boosted. Turning counterclockwise attenuates the response.

At the OFF position the tone control circuit is bypassed and frequency response is flat.

㉒ HEADPHONE JACK

Plug the headphones into this jack when you want to listen through your stereo headphones.

Release both speaker switches if you want to listen to the sound through your headphones only.

3. BLOCK DIAGRAM

RF Block

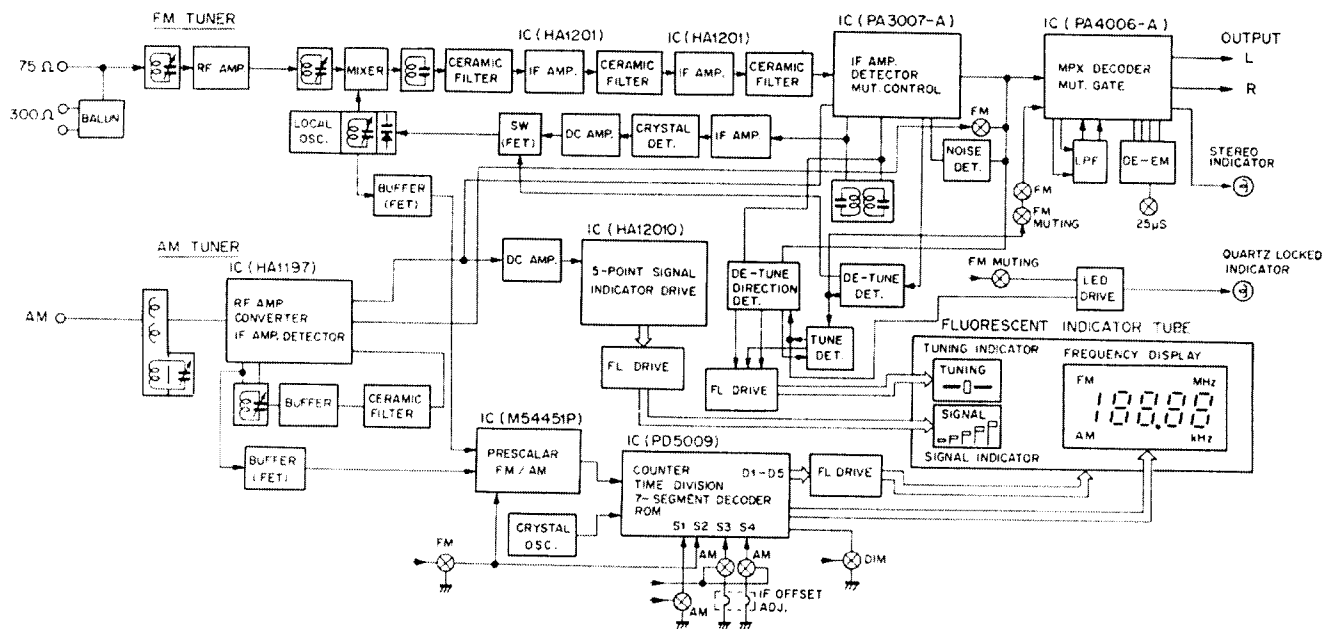

AF Block

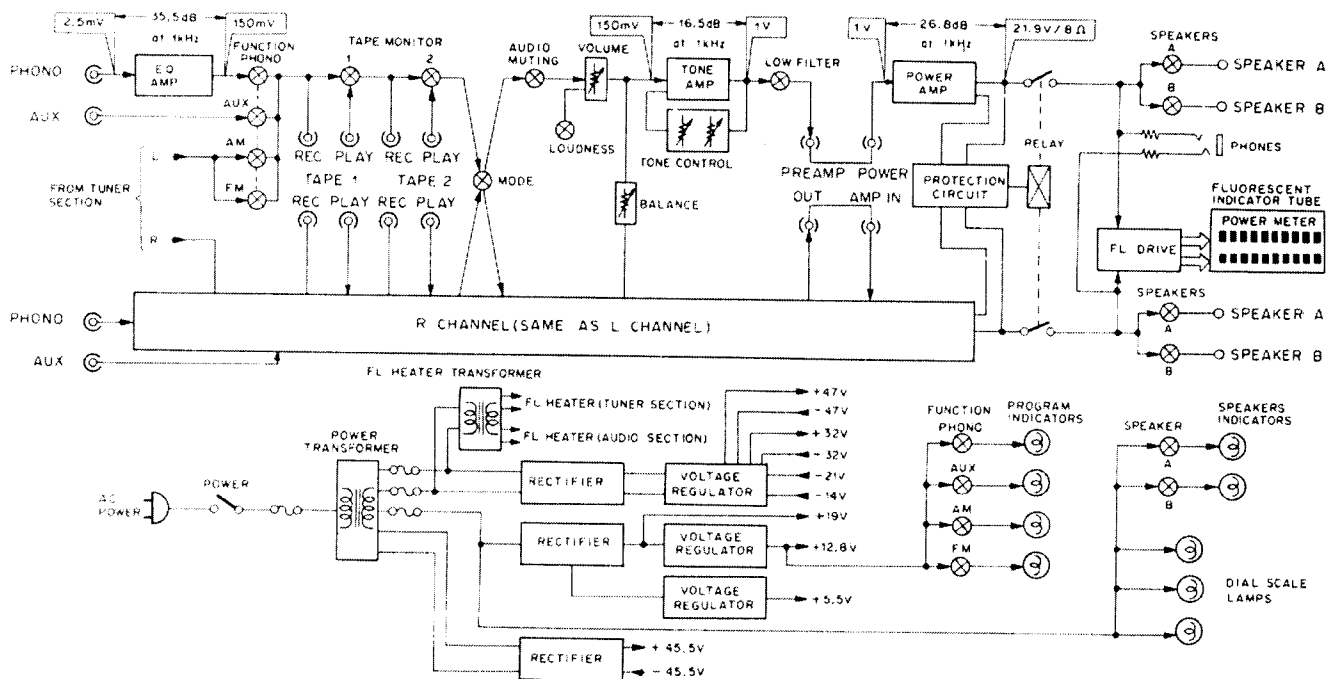

4. CIRCUIT DESCRIPTIONS

4.1 FM TUNER

Front End

The FM front end of SX-3800 includes a 3 ganged tuning capacitor, a dual-gate MOS FET-equipped 1-stage RF amplifier, and a modified Clapp circuit local oscillator. This oscillator is a voltage controlled oscillator employing a vari-cap (variable capacitance diode). When the quartz-lock system (refer to "Quartz-lock system") is not in operation, a constant voltage is applied to the diode.

IF Amplifier and Detector

These employ 3 ICs and 3 dual-element ceramic filters. The IC (HA1201) of the first 2 stage constitutes a single-stage differential amplifier current-limiting limiter. The IC (PA3007-A) in the third stage, an improvement on the former IF system IC (PA3001-A), includes an IF limiter amplifier, quadrature detector, meter drive, and other circuits. Performance in terms of distortion, S/N ratio, delay characteristics, and other parameters, shows a marked improvement in comparison to the PA3001-A.

Multiplex Decoder

The recently developed multiplex decoder IC (PA4006-A) combines MPX decoding with muting functions in a single IC, thereby handling the functions of the more conventional MPX IC (PA1001-A) and AF MUTING IC (PA1002-A).

Distortion ratings and S/N ratio have been further improved by incorporating a chopper type MPX decoder. The chopper type switching circuit (see Fig. 4-1) operates by switching the signal either to ground or to the through circuit, thereby eliminating the generation of unwanted noise or distortion. Furthermore, since the PA4006-A features DC direct-coupled switching with the detec-

tor, there is no deterioration in separation at the low frequency end.

Besides the decoder and muting circuits, the PA4006-A also incorporates the pilot signal canceler, stereo auto selector, VCO killer circuit, MUT amplifier, and MUT control circuit.

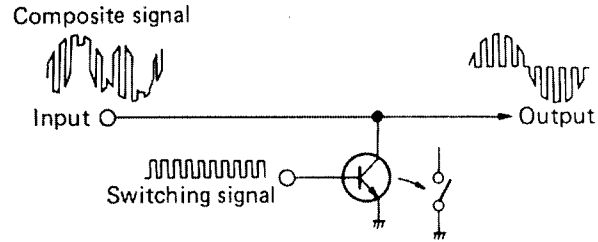

Fig. 4-1 Chopper type switching circuit

Quartz-Lock System

The quartz-lock system featured in the SX-3800 stereo receiver is a frequency servocontrol system employing a crystal resonator. Any displacement in the intermediate frequency (IF) is detected as a DC voltage by the discriminator (equipped with a crystal resonator), resulting in the local oscillator frequency being corrected and subsequently locked. This extremely stable frequency servocontrol system thus ensures that tuned frequencies remain tuned securely for as long as required.

When the IF signal appears at pin no.17 of the IF system IC (PA3007-A), it is amplified and applied to crystal detector (see Fig. 4-2) which consists of diodes connected in parallel in a series resonance circuit equipped with a crystal resonator. The resonance frequency is the same as the IF frequency (10.7MHz), which means the impedance at this time will be minimal, resulting in the output being reduced to a minimum level. If the input frequency increases, the reactance of the capacitance

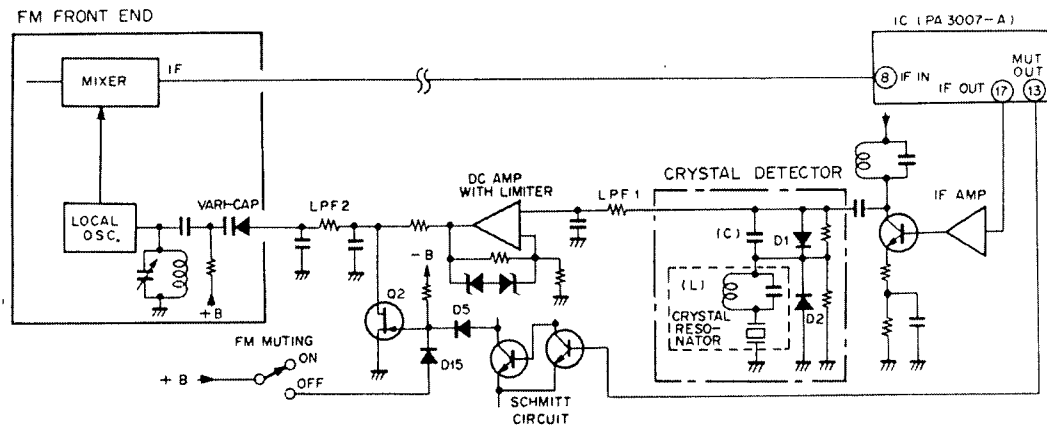

Fig. 4-2 FM quartz-lock system

stage (C) is reduced, and the reactance of the inductance stage (L) increased, resulting in AM detection by D2 which leaves the positive portion of the IF signal. If the input frequency decreases, L stage reactance is decreased and C stage reactance increased, resulting in AM detection by D1 which leaves the negative portion of the IF signal. The L stage and C stage reactances increase as the degree of detuning in the respective directions is increased, resulting in a subsequent increase in the detector output. By thus attaining S-curve characteristics, FM detection becomes possible. Since the IF signal is an FM signal frequency deviation due to modulation will be symmetrical about a central axis. And if the central frequency is equal to the resonance frequency, the detector output DC level will be zero. If, however, there is any displacement in the central frequency, frequency deviation in respect to the detector will become asymmetrical, resulting in the generation of a DC voltage. This DC voltage is passed through LPF1 (IF filter) and LPF2 (AC filter) to form a correction voltage which is applied to the variable capacitance diode in the local oscillator, thereby correcting the oscillator frequency to obtain a constant IF (i.e. a constant tuned frequency).

Since the central frequency of the crystal detector is regulated by the crystal resonator, tuned frequencies of extremely high stability are obtained.

• Limiting the Locking Range

If the quartz-lock range is too wide, it will overlap with strong adjacent broadcasting frequencies and result in considerable tuning difficulties. A DC amplifier is therefore used as a limiter (limiter action by NFB circuit zener diodes) which restricts the voltage applied to the variable capacitance diode, thereby limiting the quartz-lock range.

A DC voltage appears at pin no.13 of the IF system IC (PA3007-A) when the antenna input level drops below $5\mu V$, or when the tuned frequency has been detuned by more than $\pm 100kHz$. This DC voltage (FM muting signal) is applied to the gate of Q2 (FET) via a Schmitt circuit, resulting in the FET being turned on, and the quartz-lock circuit being turned off.

4.2 AM TUNER

The AM tuner section consists of a 2-ganged tuning capacitor plus an IC (HA1197) which contains a 1-stage RF amplifier, converter, 2-stage IF amplifier, detector, and AGC circuit.

The AM STEREO OUT terminal on the rear panel is for connecting to an AM stereo broadcast decoder adaptor. The signal appearing at this terminal is the converter output passed via a buffer (emitterfollower) stage.

4.3 DISPLAY CIRCUIT

Frequency Display

Frequencies received by the SX-3800 are displayed in digital form by fluorescent indicator tube (FL tube). Each digit employs up to 7 segments (a ~ g) (see Fig. 4-3) to display all numerals from 0 to 9 (with the exception of the left hand digit which employs only 2 segments b and c).

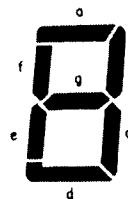

Fig. 4-3 7-segment digit display

The signal source during both AM and FM reception is the local oscillator. The signal is passed via a buffer amplifier (FET) to the prescaler IC (M54451P) where it is subjected to frequency division (1/8 for AM and 1/80 for FM) before being applied to the frequency counter IC (PD5009). This IC is responsible for the dynamic drive of the 7-segment 5-digit display (each digit being turned on according to time-shared sequential scanning).

An outline of the composition of PD5009 is given in block diagram form in Fig. 4-5. With the FL tube a ~ g segments (anode) for each digit connected in parallel, the D1 ~ D5 time division pulse signals (see Fig. 4-6) applied to each grid (independent grid for each digit) result in the digits being lit up in succession from the left hand side. Each digit is lit up for 1ms during each 5ms inter-

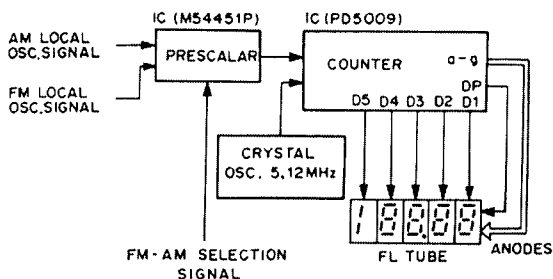

Fig. 4-4 Frequency display block diagram

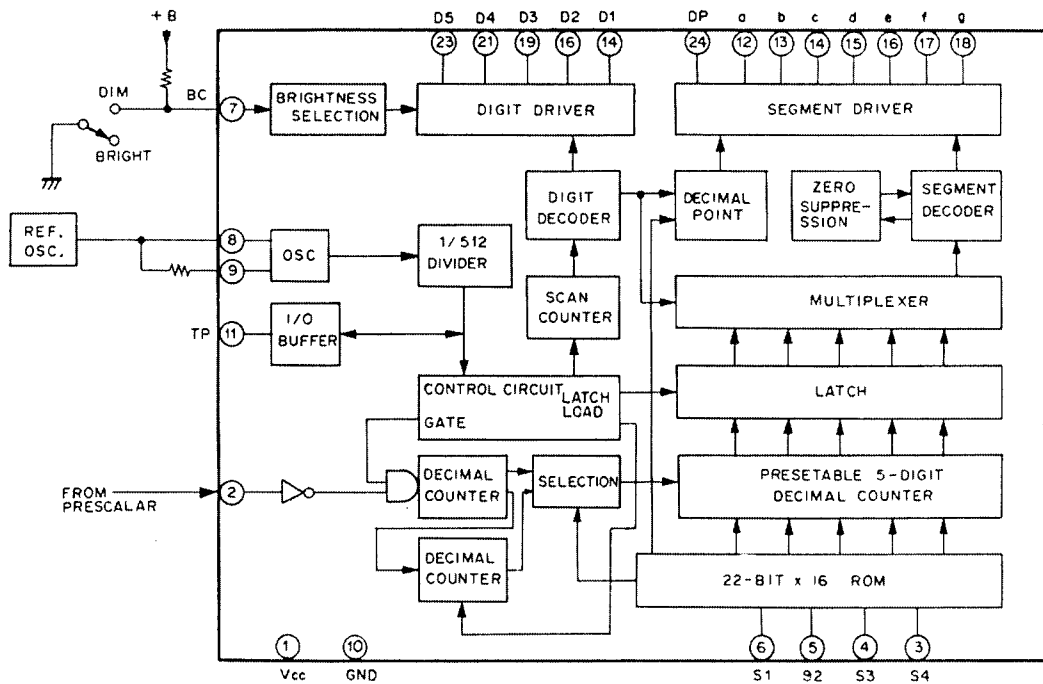

Fig. 4-5 Block diagram of PD5009

val. Pin no.7 of PD5009 is the brightness selector terminal. The time division pulse width is set to $800\mu\text{s}$ for H level input signals, and to $200\mu\text{s}$ for L level signals, thereby varying the degree of FL tube brightness (by varying the segment lighting period). Note that since the power indicator FL tube is driven by static drive, the degree of brightness may be varied by changing the grid voltage.

The 5.12MHz crystal oscillator generates the basic signal used in the preparation of the time division pulse signal and the counter gate circuit control signal.

Terminals S1 ~ S4 (pin nos.3 ~ 6) are used in designating reception mode. The 2 reception modes employed in the SX-3800 (see Table 1) are designated by varying the combination of input levels (H and L). The 3 different IFs during FM mode are required in coping with IF offset in the IF ceramic filter stage, S3 and S4 being preset during FM mode according to the ceramic filter characteristics.

Although the SX-3800 FM stage quartz-lock system is capable of locking any frequency within the FM band, the 10kHz digit (digit in the second decimal place) in the FM frequency display will appear only as 5 or 0.

The frequency display FL tube also incorporates the TUNING and SIGNAL indicators. And although the segments (anode) for these indicators are static driven by the corresponding drive circuits, the grid is driven according to the D3 time division pulse timing, thereby placing the segments

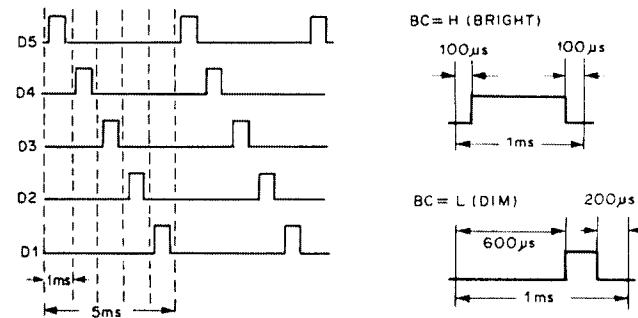

Fig. 4-6 D1-D5 time division pulse signals

under dynamic drive. In addition, the AM and FM indicators in the frequency display section are lit according to the D5 timing, while the kHz and MHz indicators are lit according to the D1 timing.

MODE	S1	S2	S3	S4	IF (MHz)
FM	H	L	L	H	10.73
	H	L	H	L	10.70
	H	L	H	H	10.67
AM	L	H	H	L	450kHz

Table 1

SIGNAL Indicator Circuit

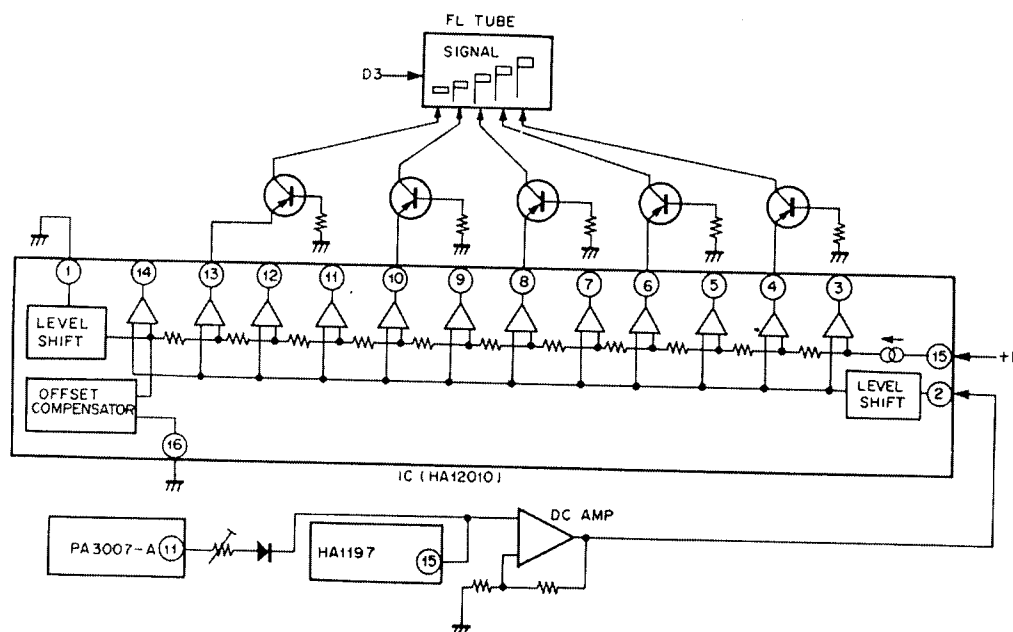

Fig. 4-7 SIGNAL indicator drive circuit

The SX-3800 SIGNAL indicator consists of an FL tube 5-point indicator display. The signal meter drive signal obtained from the FM IF system IC (PA3007-A) and AM tuner IC (HA1197) is first amplified and then applied to the indicator drive IC (HA12010). This IC contains 12 pairs of voltage comparators similar to those employed in the power indicator circuit, 5 of these pairs being used to drive the SIGNAL indicator.

TUNING Indicator Circuit

The TUNING indicator consists of a center tuning indicator (which lights up when a broadcasting station frequency is properly tuned) and 2 detuning direction indicators which indicate the direction in which the station has been tuned away from. The corresponding drive circuits are outlined in Fig. 4-8 below.

The TUNING indicator is activated once the station has been tuned to within $\pm 100\text{kHz}$ of the center frequency. This is because Q16 is turned on and Q21 turned off (resulting in the detector differential amplifier [Q19 & Q20] being turned off and Q24 being turned on) by the FM muting signal appearing at pin no.13 of the IF system IC (PA3007-A) and passed via the Schmitt circuit (Q17 & Q18) when the station is tuned away by more than $\pm 100\text{kHz}$.

The DC voltage on pin no.4 of PA3007-A describes an S curve when tuning to and away from a particular broadcasting frequency, the voltage on pin no.2 serving as the reference level. This DC

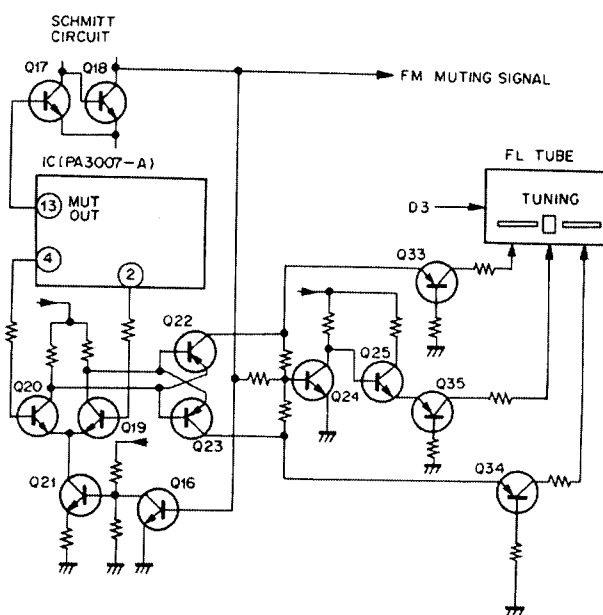

Fig. 4-8 TUNING indicator drive circuit

voltage is amplified by the differential amplifier (Q19 & Q20) and then applied to a polarity detector switch circuit (Q22 & Q23).

When tuning to a frequency from the high frequency side (or tuning away from the frequency to a higher frequency), the voltage on pin no.4 will be higher than that on pin no.2. The Q20 collector voltage will thus be lowered and the Q19 collector voltage will be raised, resulting in Q23 being turned on, and the higher frequency (right hand side) detuning direction indicator also being turned on. When,

on the other hand, the broadcasting frequency is approached from the low frequency side (or when tuning away to a lower frequency) the pin no.4 voltage will be lower, resulting in Q22 being turned on to light up the lower frequency (left hand side) detuning direction indicator. When either Q22 or Q23 is on, the Q24 base voltage will be high, resulting in Q24 being turned on and Q25 turned off, which means that the center tuning indicator will not be lit up.

Once the broadcasting frequency has been tuned properly, the voltages on pin nos.2 & 4 will be equal. Consequently, Q22 and Q23 will both be turned off, which means that neither of the detuning direction indicators will be on in this case. And since Q24 is turned off because of the decreased base voltage, Q25 will be turned on, and the center tuning indicator light up. Furthermore, C77 is charged up via R99, resulting in Q26 being turned on, thereby lighting up the Quartz Locked indicator LED.

4.4 EQUALIZER AMPLIFIER

This circuit is an NFB type equalizer amplifier with newly developed high performance IC (HA12017P).

This IC is a low-noise and low distortion type, and provide an openloop gain of 105dB. The main performance specifications for this circuit include a voltage gain of 35.5dB (at 1kHz), a phono dynamic margin or maximum allowable input level of 250mV (1kHz, 0.005% THD), S/N ratio of 82dB (at 2.5mV input, IHF-A), and equalization within ± 0.2 dB (20Hz - 20kHz).

4.5 TONE CONTROL AMPLIFIER

This circuit is an NFB type tone control amplifier with newly developed high performance IC (HA12017P).

4.6 POWER AMPLIFIER Amplifier Circuit

The basic circuit arrangement of the power amplifier is shown in Fig. 4-9. The first stage is a differential amplifier comprising PNP twin transistor (Q2), the load circuit of which is a current mirror employing an NPN twin transistor (Q3). The current mirror provides push-pull operation in this stage, which serves to cancel even harmonics and further increase gain.

Q1 in the input circuit absorbs outflow of base current from Q2, and prevents the generation of a DC voltage. Because Q1 follows any temperature drift in Q2, temperature drift of the center point voltage is prevented.

The pre-driver stage (Q4, Q5) is a Darlington arrangement, the load circuit of which employs a constant-current source (Q6) resulting a high voltage gain.

The power stage bias voltage is supplied by the high speed bias servocontrol circuit. The high speed bias servocontrol circuit provides non-switching operation in the power stage (refer to "High Speed Bias Servocontrol Circuit").

The power stage (Q13 - Q16) is a 2-stage Darlington arrangement, the last stage is SEPP circuit employing an SL RET (Super Linearity Ring Emitter Transistor). The RET is a kind of IC consisting of a number of small transistors on a single chip, with each transistor being connected in parallel via an emitter resistor. This provides

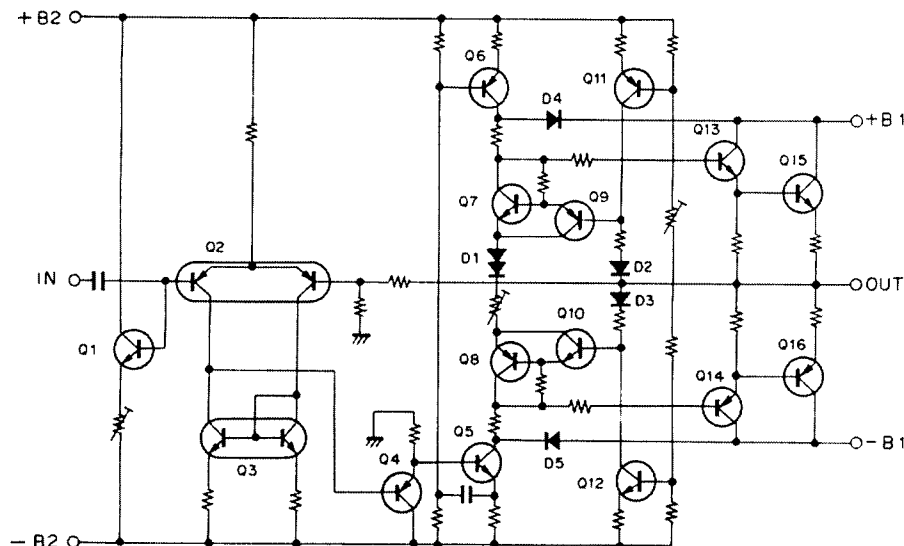

Fig. 4-9 Power amplifier

excellent high frequency characteristics comparable to those of a small-signal transistor. Furthermore, because there is no time constant in the NFB circuit in the low-frequency region, amplification is possible down to DC (DC inputs will be cut off, however, by the input coupling capacitor).

The circuit features described above provide an extremely wide power frequency range (60W + 60W, 10Hz to 20kHz, THD 0.005%, 8Ω).

High Speed Bias Servocontrol Circuit

By operating the power stage only within the active region (no possible cut-off) and with minimum idle current, the high speed bias servocontrol circuit prevents the generation of switching distortion and reduces heat loss.

Operating Principle

Since idle current flows through normal class B SEPP power stages (see Fig. 4-10) when no signal is applied, the DC level is shifted by D and VR by a fixed amount (with the voltage across points X and Y serving as a bias). The voltages across points X and Z, and Z and Y at this time will be equal. When the positive portion of a signal is applied to this circuit, the power stage current on the NPN side is increased, and the voltage (VE1) across both ends of RE1 also being increased, resulting in the voltage across point X and Z being increased. However, since the voltage across points X and Y is practically constant, the voltage across points Z and Y (PNP power stage bias) will be decreased, resulting in the PNP power stage being cut off.

The high speed bias servocontrol circuit increases the voltage across points X and Y by the same amount as the voltage increase across points X and Z, thereby cancelling the voltage decrease across points Z and Y, and preventing the PNP power stage from being cut off.

This high speed bias servocontrol circuit is outlined in Fig. 4-11. When there is no signal applied to the circuit, Q1 and Q2 are almost cut off, while Q3 and Q4 will be on. The voltage across the collector and base of both of these transistors (Q3 and Q4) at this time may be disregarded. Consequently, with the power stage bias circuit consisting of 4 PN junctions formed by Q3, D3, and Q4, and VR1, this circuit is equivalent to the previous circuit shown in Fig. 4-10.

With R1 and D1 ensuring a constant flow of current, the base of Q1 and point Z may be brought to the same level on an AC basis (level fluctuations due to the signal) by a simple shift in DC level. Furthermore, Q1 may be considered emitter-follower with R3 as the emitter resistance.

When the voltage across points X and Z is increased by the positive portion of the signal applied to this circuit, it becomes the input signal of this emitter-follower (Q1). Since the emitter-follower voltage gain is practically 1, a voltage more or less equal to that of the input signal (that is, the voltage increase across points X and Z) is produced at R3. And the R3 voltage is the voltage applied across the base and collector of Q3 which forms part of the power stage bias circuit. So the bias voltage applied to Q3 will be in excess by the same amount that the voltage across points X and Z is increased (by positive portion of the signal) above the voltage level when no signal is being applied. Consequently, the increase in voltage across points X and Z cancels the decrease in voltage across points Z and Y, thereby maintaining the idle current without cutting the PNP power stage off (noting that there actually is a slight decrease in current). For the negative portions of the signal, Q3 and Q4 are operated in the same manner, thereby preventing the NPN power stage from being cut off.

In other words, the high speed bias servocontrol circuit acts to prevent any "power stage cut-off" signals from being applied to the power stage.

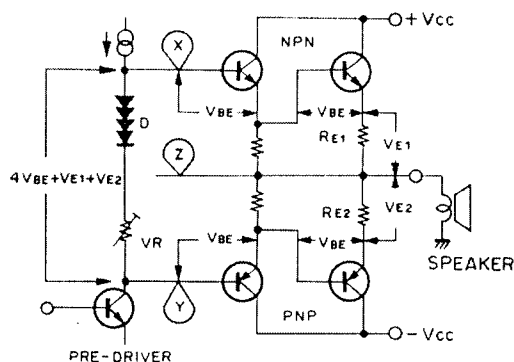

Fig. 4-10 Normal power stage bias circuit

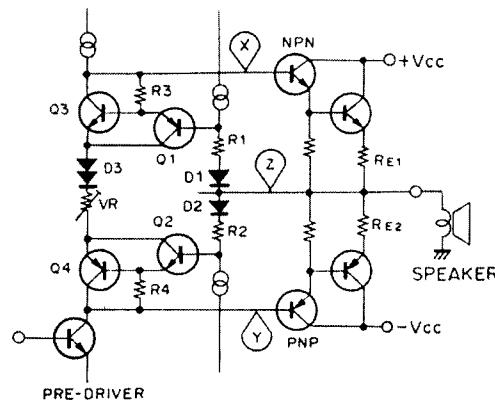

Fig. 4-11 High speed bias servocontrol circuit

4.7 POWER INDICATOR CIRCUIT

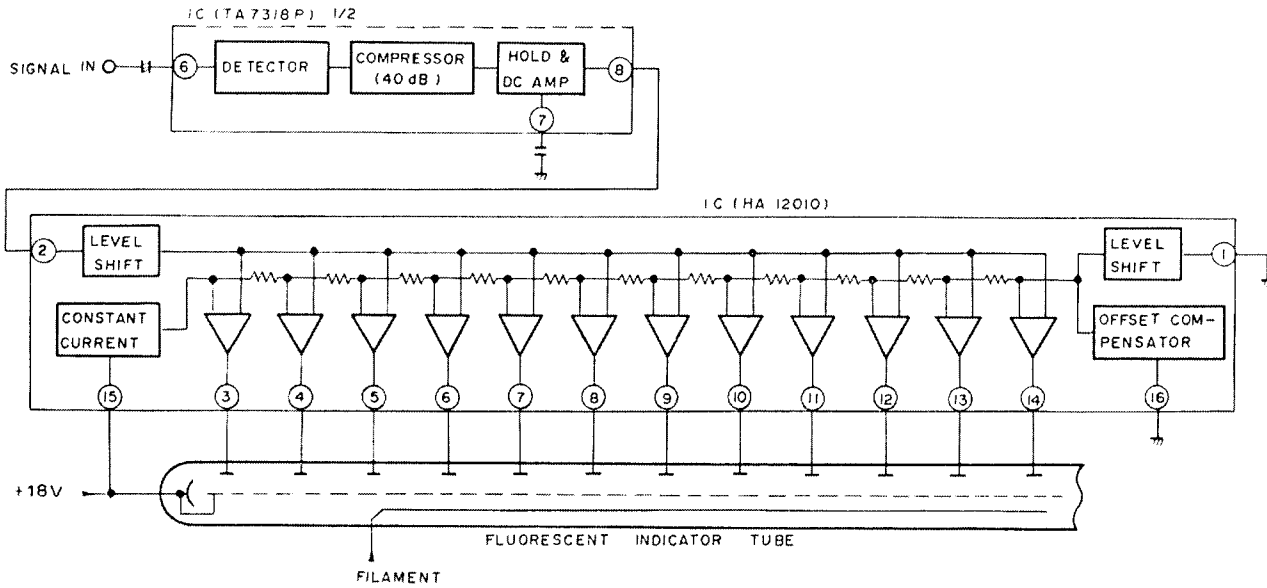

Fig. 4-12 Power indicator circuit

The SX-3800 output power indicators feature fluorescent indicator tube (FL tube). In this tube, thermionic emissions from the cathode are accelerated into the fluorescent substance of the segmental anodes, resulting in the emission of light. This tube is used to indicate numerals, letters, and other symbols.

An outline of the FL tube drive circuit is shown in Fig. 4-12. The output circuit signal is applied to pin no.6 (4) of the IC (TA7318F-A). The IC contains a detector circuit, compressor (40dB), and peak hold circuit for both left and right channels. The dynamic range of the signal is thus contracted by 40dB to obtain a "peak held" DC voltage.

The output power indicator segments of the FL tube are driven by the HA12010 ICs (one for each channel) equipped with 12 pairs of differential amplifiers. These amplifiers are biased at increasing levels, so each amplifier will commence to operate separately as the input level increases. And since these amplifiers apply the voltages to the output power indicator segments, each successive segment will light up in turn as the input level rises.

4.8 PROTECTION CIRCUIT

The purpose of this circuit is to protect the speakers and the power amplifiers. The relay in the output circuit is automatically opened in any of the following cases:

1. During the "transient operations" when the power supply is turned on and off.
2. Upon detection of an overload, caused by a short circuit in the load.
3. Upon detection of a DC voltage in the output caused by component failure or accident.

Muting Operation when Power Supply is Turned On and Off

With reference to Fig. 4-13 when the power supply is turned on, Q3 turns off due to -B1 (The time constant of the -B1 circuit is very small.). If there is no input (DC) on Q5 and Q6, they will be off, and the timing capacitor C1 charges up through R8 and R6, and thus Q4 turns on. When Q4 conducts, the relay operates, and the output muting on the power amplifier will be removed.

When the power supply is turned off, -B1 will abruptly decay, and Q3 will conduct owing to the residual component of +B1. As a result, C1 will rapidly discharge, Q4 will cease to conduct, whereupon the relay will become de-energized and restore muting.

Overload Detector

The overload detector circuit incorporates the load (RL) in one side of a Wheatstone bridge. The base and emitter of a sensing transistor (Q1) are connected to the opposite corners of the bridge, so if RL decreases, Q1 will become forward biased. If RL falls below a prescribed value, Q1 will turn on, thereby C1 will rapidly discharge. As consequence, Q4 will turn on and the relay will become deenergized, thus causing the output circuit to open.

DC Voltage Detector

The output circuit is connected to the Q6 emitter and Q5 base via a low-pass filter (R9, C2). Any DC voltages appearing the output circuit of the power amplifier, it will be applied to the Q6 emitter and Q5 base. If the voltage is positive, Q5 turns on. C1 will rapidly discharge. If the voltage is negative, Q6 turns on. C1 will rapidly discharge. As consequence, Q4 will turn on and the relay will become de-energized, thus causing the output circuit to open.

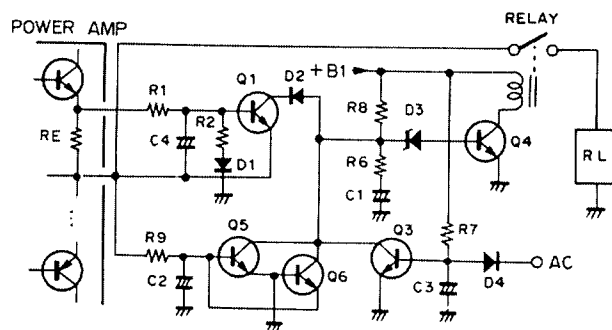

Fig. 4-13 Protection circuit

5. DISASSEMBLY

Bonnet Case

Remove the two screws **1** on each side of the bonnet case.

Bottom Plate

Remove the fifteen screws **2** to detach the bottom plate.

Front Panel

Remove the all control knobs except push knobs. Remove the two screws **3** and two nuts **4** from the front panel.

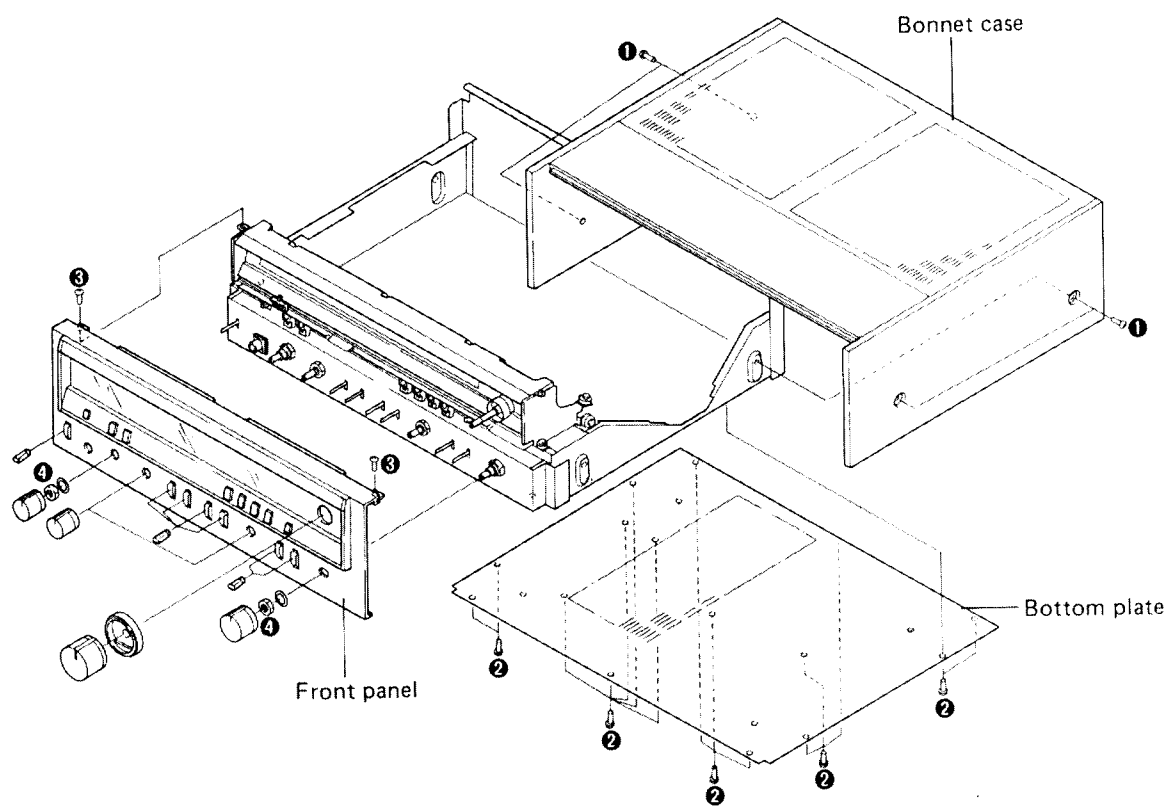

6. PARTS LOCATION

- The  mark found on some component parts indicates the importance of the safety factor of the part. Therefore, when replacing, be sure to use parts of identical designation.

Front Panel

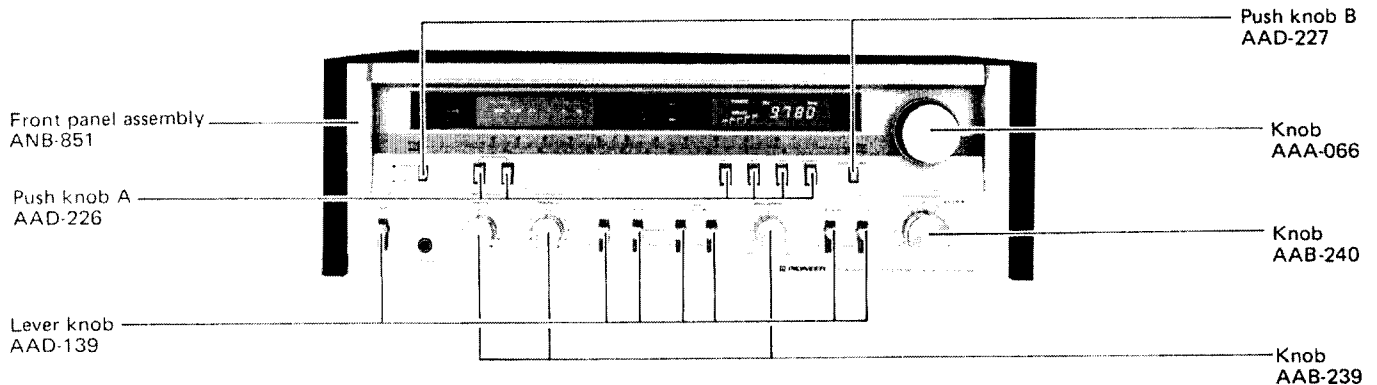

Front View with Panel Removed

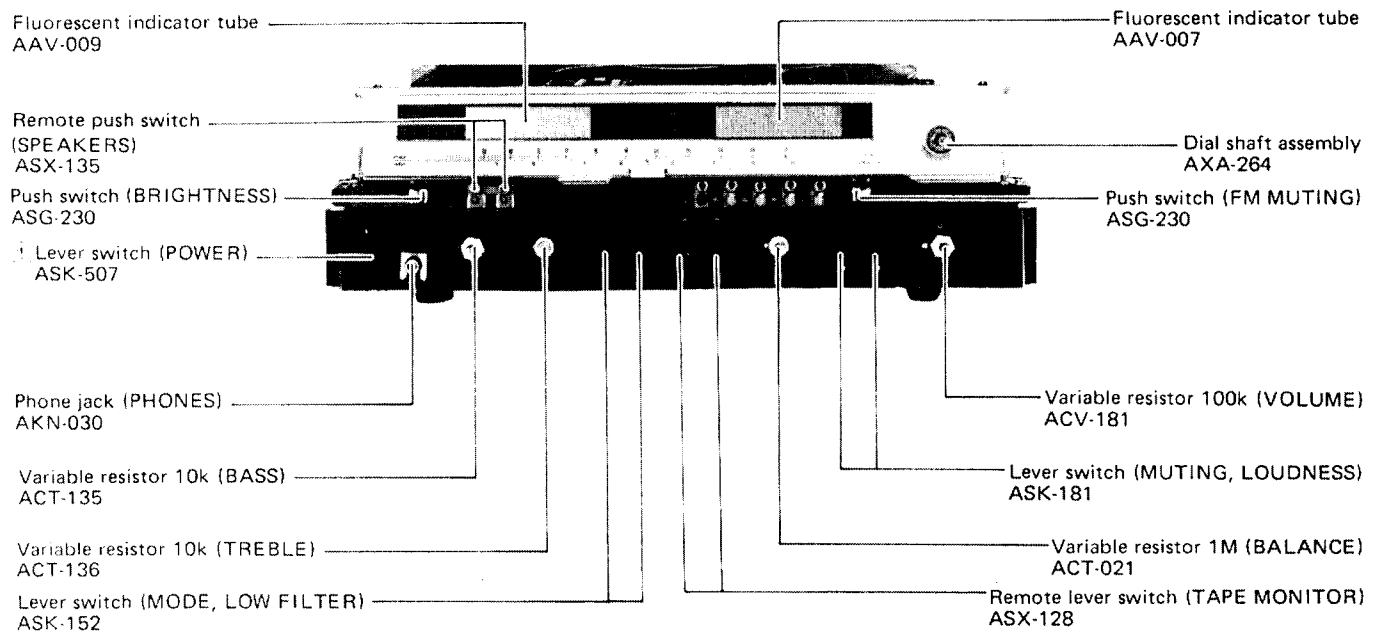

Rear Panel

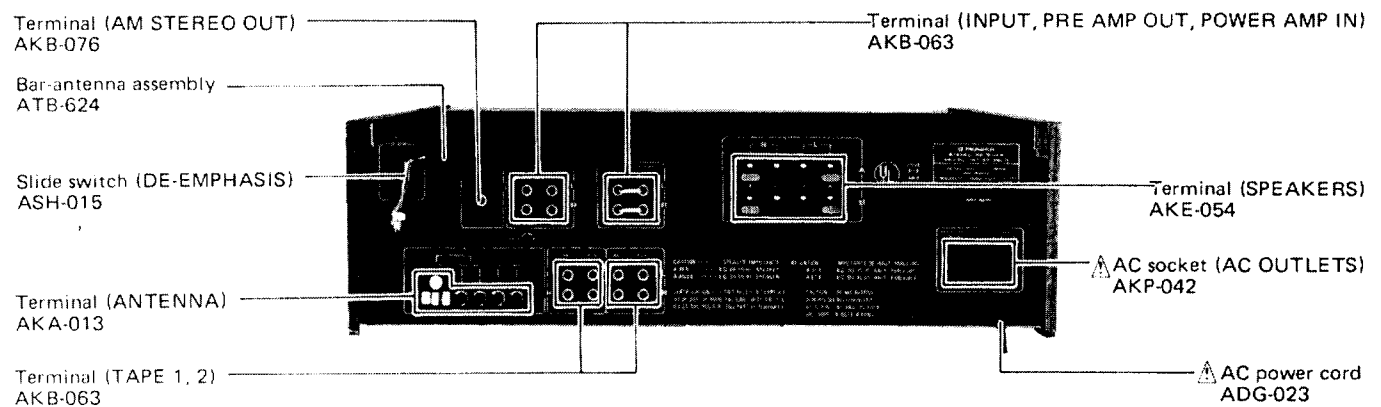

10.2 P.C. BOARD CONNECTION DIAGRAM

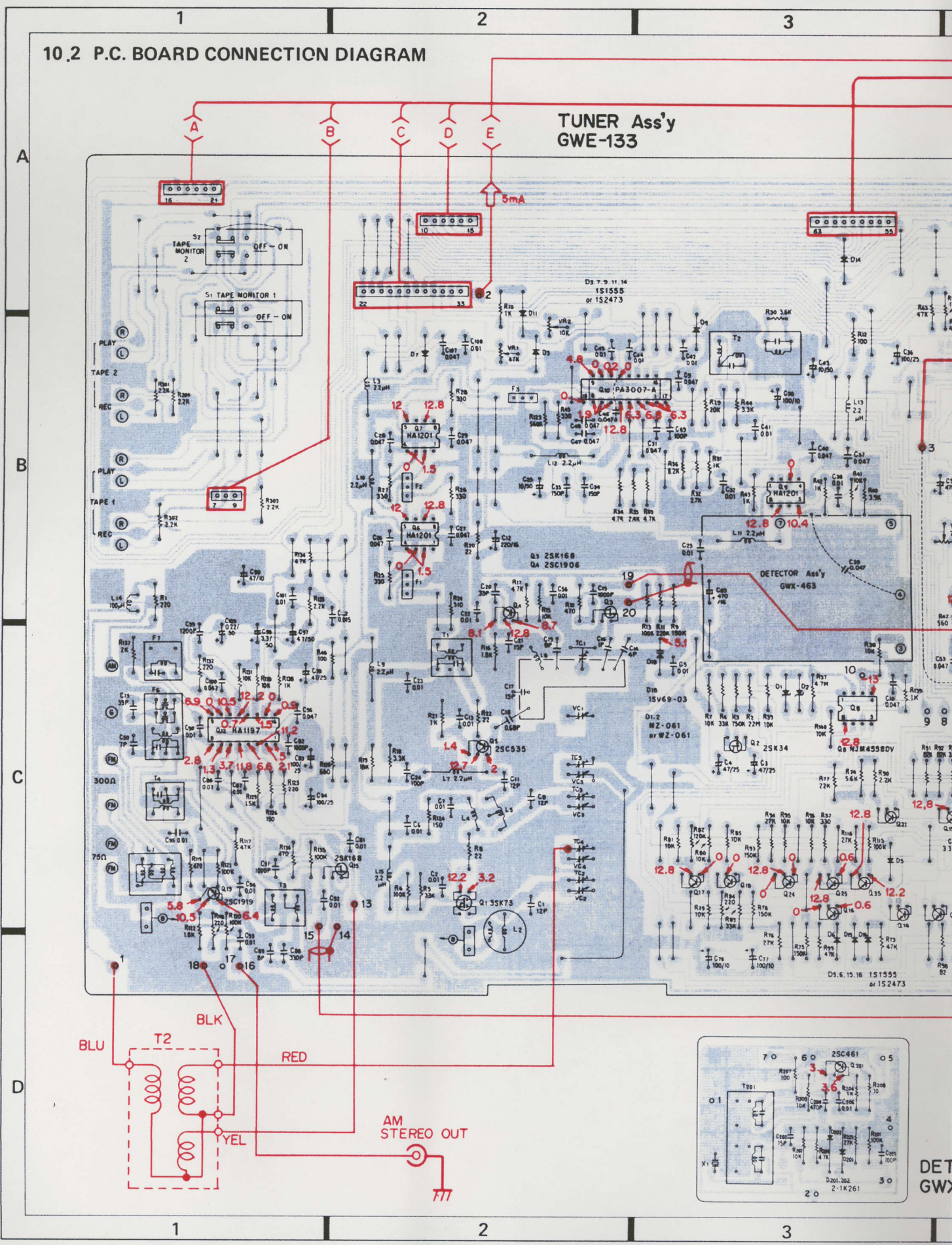

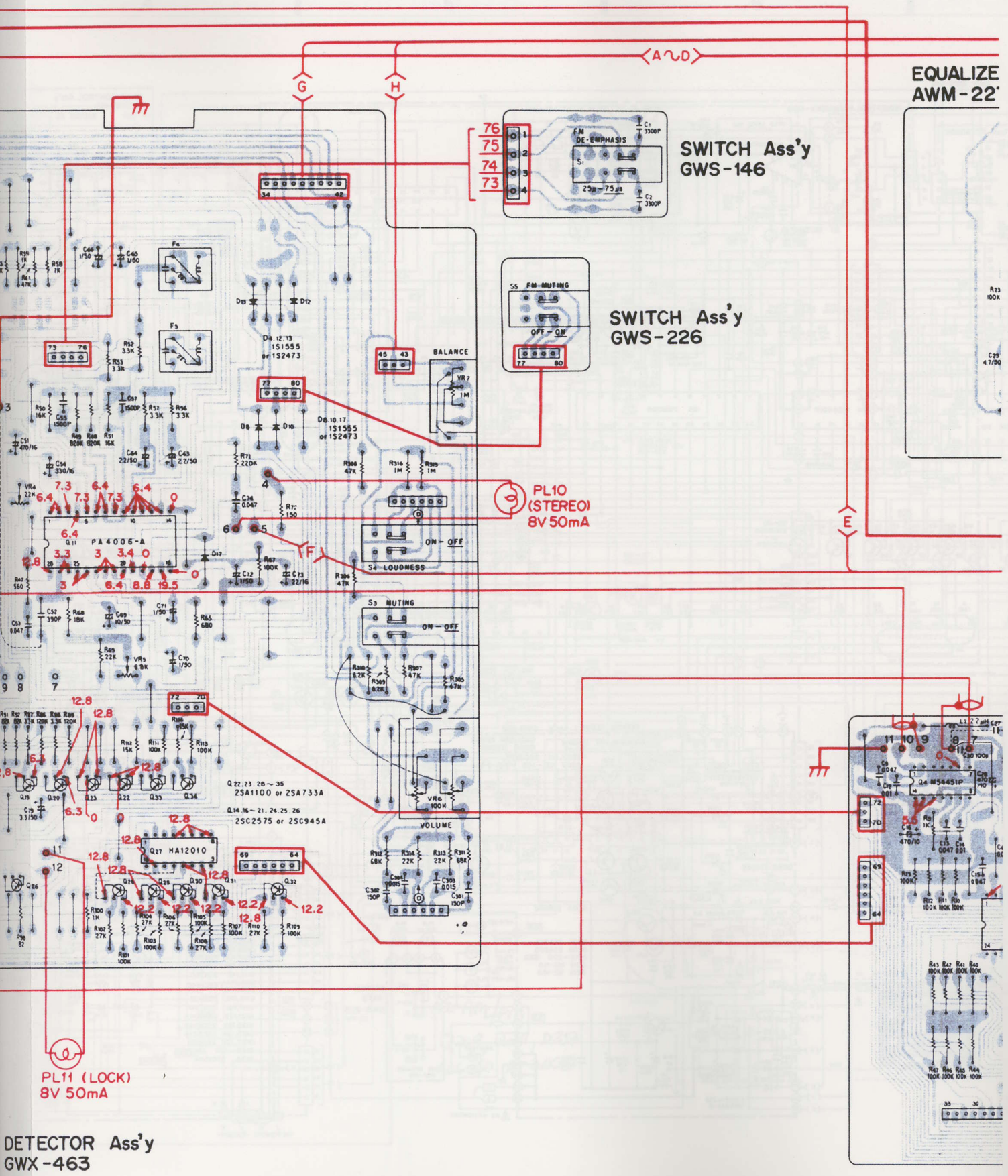

EQUALIZE
AWM-22'

SWITCH Ass'y
GWS-146

SWITCH Ass'y
GWS-226

PL10 (STEREO)
8V 50mA

PL11 (LOCK)
8V 50mA

DETECTOR Ass'y
GWX-463

**EQUALIZER Ass'y
AWM-227**

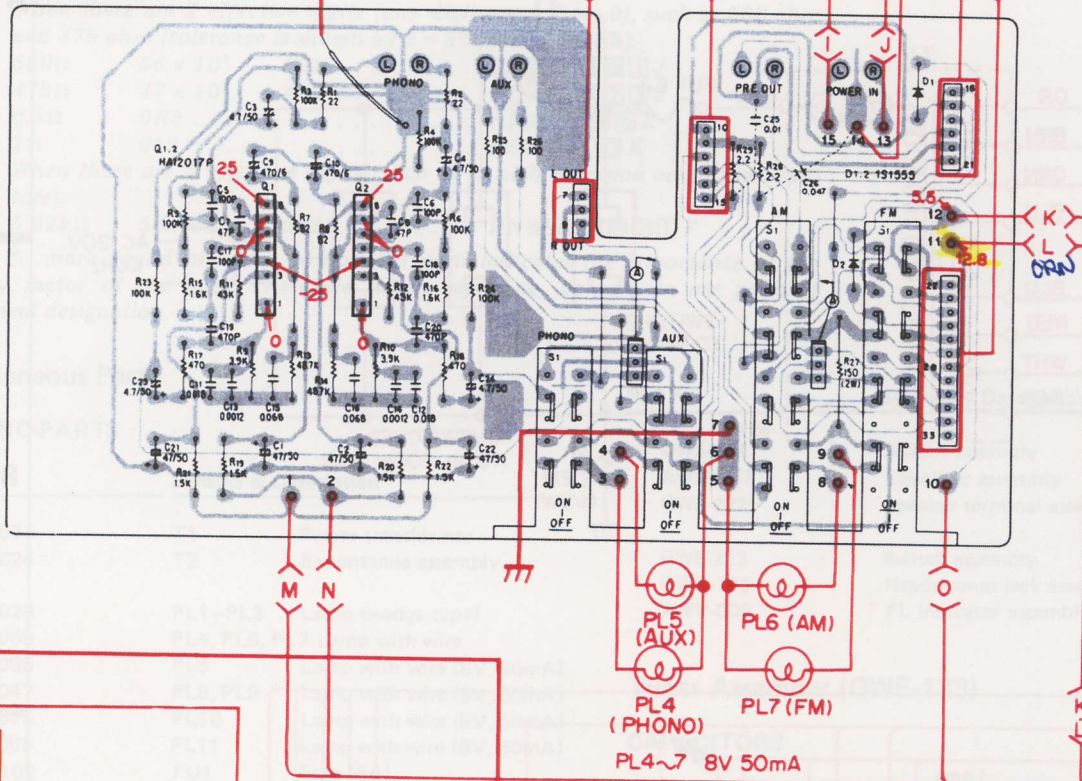

- The counter IC (PD5009 (AWV-009) has been des values by appropriate co or L level signals) applie the wiring (connecting within the equalizer ass differ slightly from the ci the grade of the FM ce into 3 ranks according to
- The R28 and R29 resist (AWM-227) constitute th match the counter IC (PL assembly) with the FM I have been arranged acco mic filter F1 ~ F3 (color in the following table.

FM ceramic filter (F1-F3)	R
Red	
.Blue	
Orange	

**INDICATOR Ass'y
AWV-009**

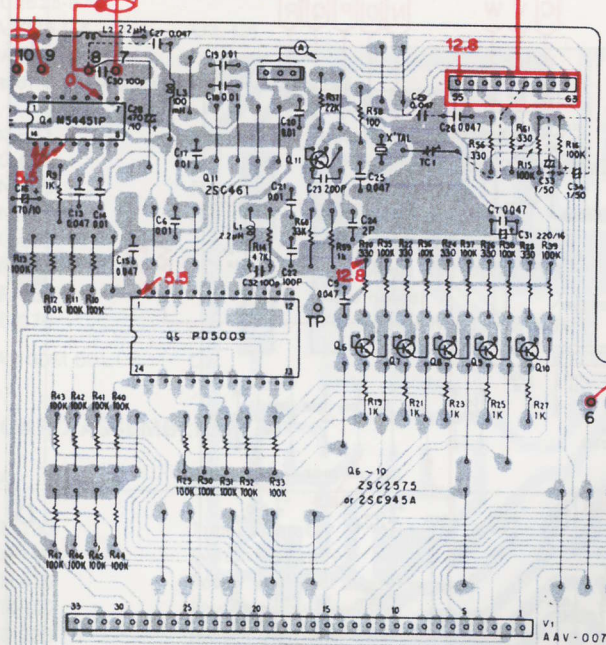

**SWITCH Ass'y
GWS-224**

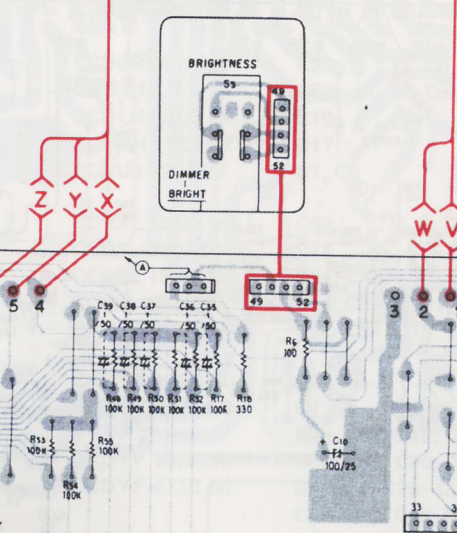

5009) in the indicator assembly designed to match FM IF offset combination of input signals (H applied to pin nos.3 & 4. Note that ng pin nos. 3 & 4 of PD5009) assembly (AWM-227) may thus e circuit diagram, depending upon ceramic filters F1 ~ F3 (divided to IF offset value).

resistors in the equalizer assembly the program circuits employed to (PD5009 located in the indicator FM IF offset value. These jumpers according to the grade of FM cera- color coded into 3 ranks) as shown

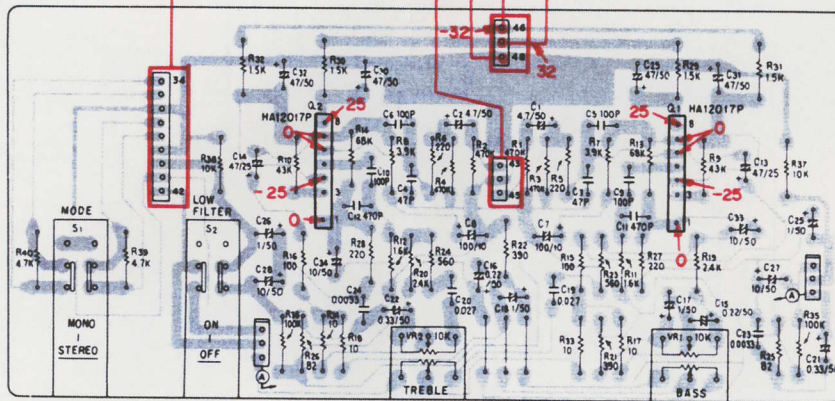

**TONE CONTROL Ass'y
GWG-141**

AWM-227

R28(2.2Ω)	R29(2.2Ω)
Cut	Connect
Cut	Cut
Connect	Cut

**HEADPHONES JACK Ass'y
GWK-146**

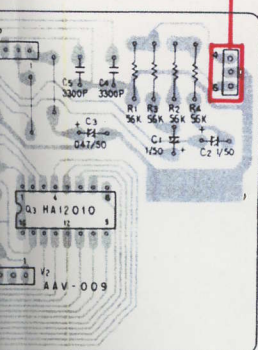
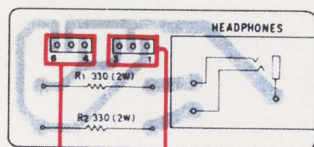

SPEAKER TERMINAL Ass'y GWS-222

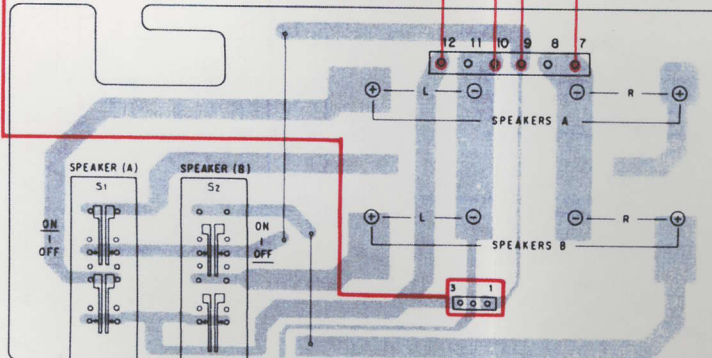

- <K~O>
- <E,F>
- <V~Z>
- <R~U>

- B
- C
- D
- E
- F

POWER AMP Ass'y GWH-139

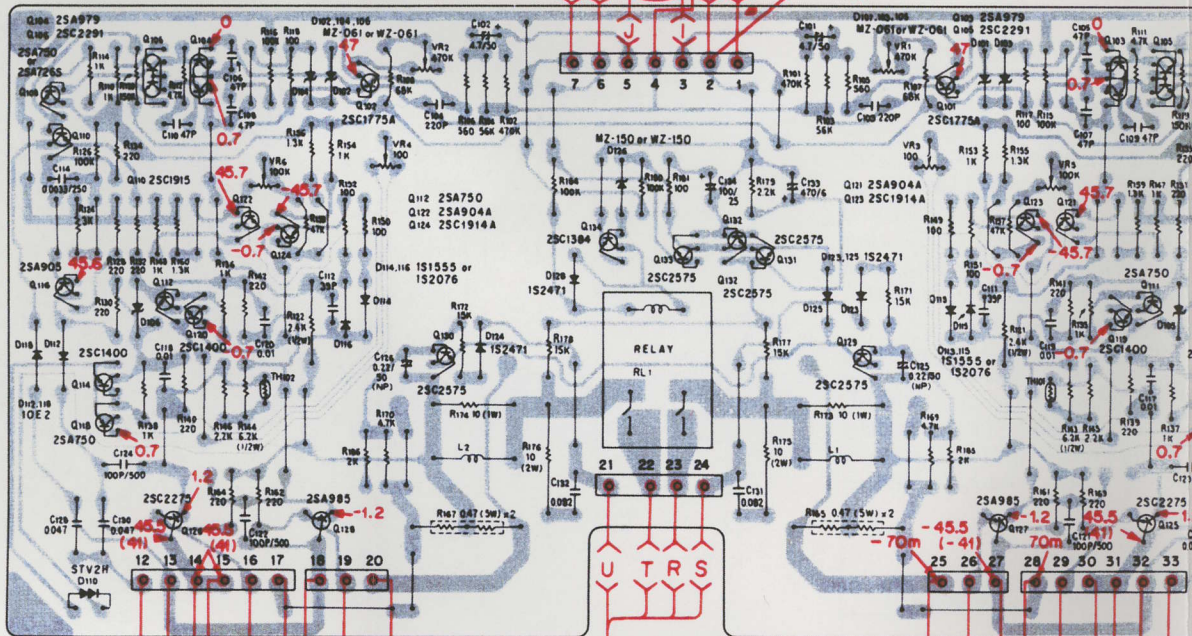

- B** ← < K ~ O >
- C** ← < E, F >
- D** ← < V ~ Z >
- E** ← < R ~ U >
- F** ← < P, Q >

POWER SUPPLY Ass'y GWR-122

Foil Side

SWITCH Ass'y GWS-223

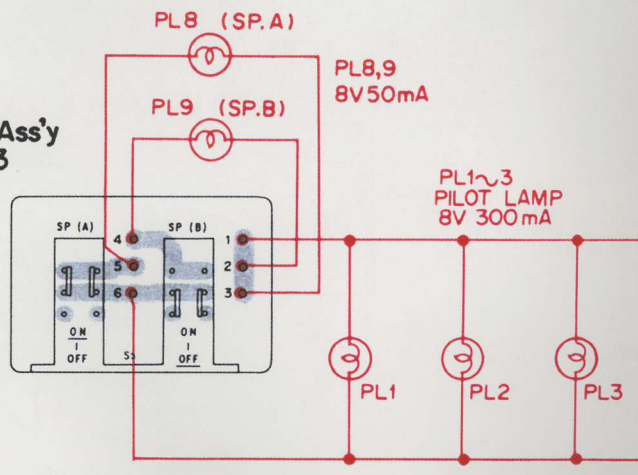

4

5

6

A

B

C

D

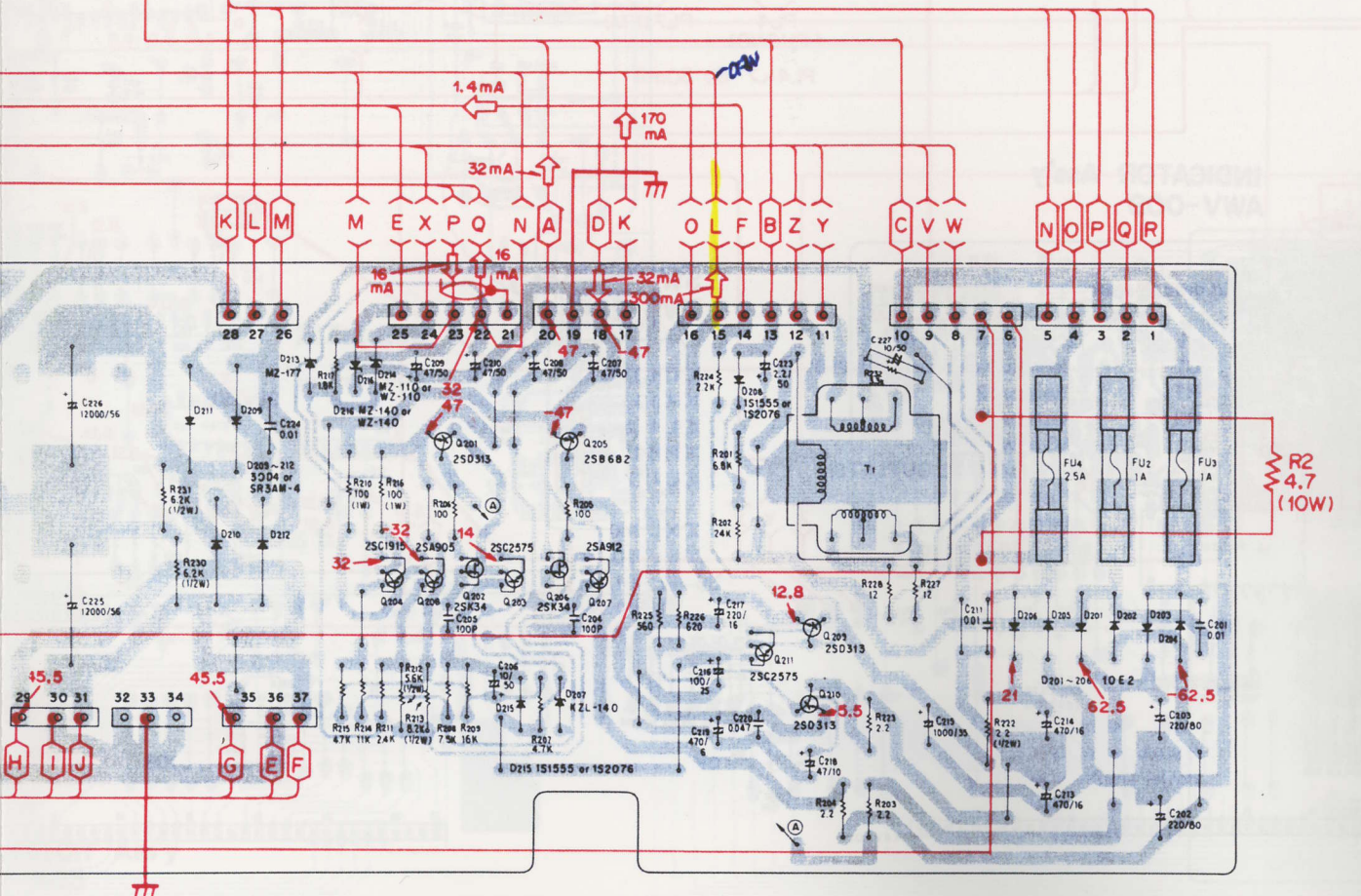
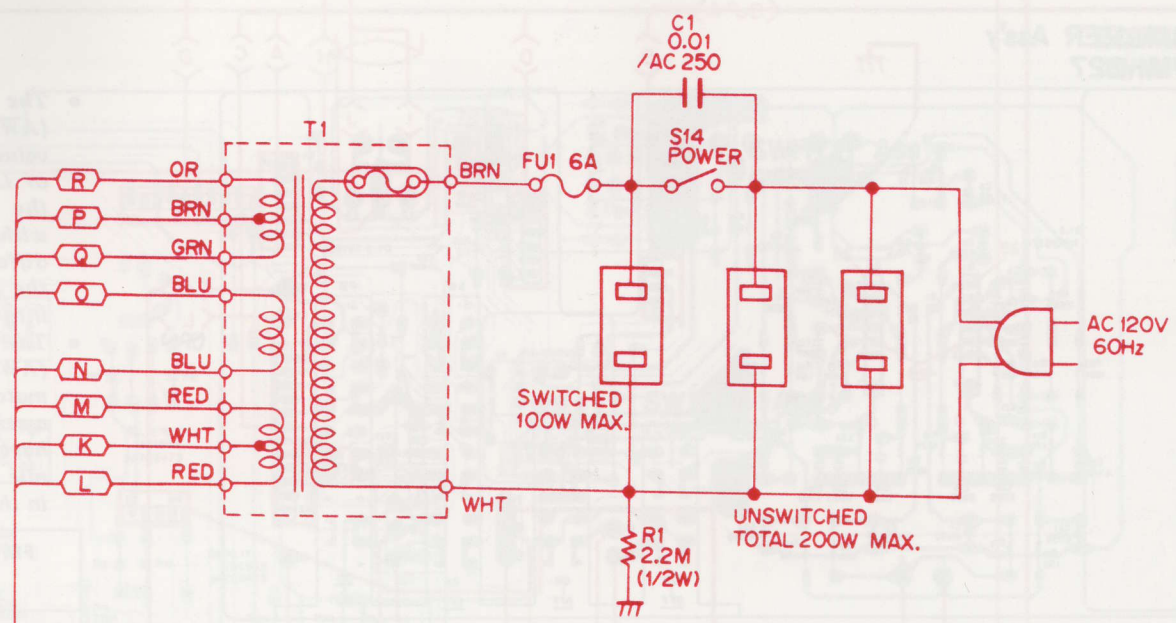
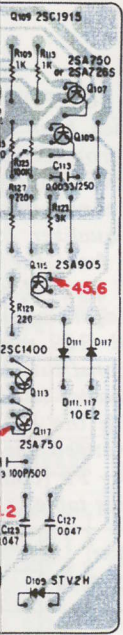

4

5

6

10.1 SCHEMATIC DIAGRAM

A

B

C

D

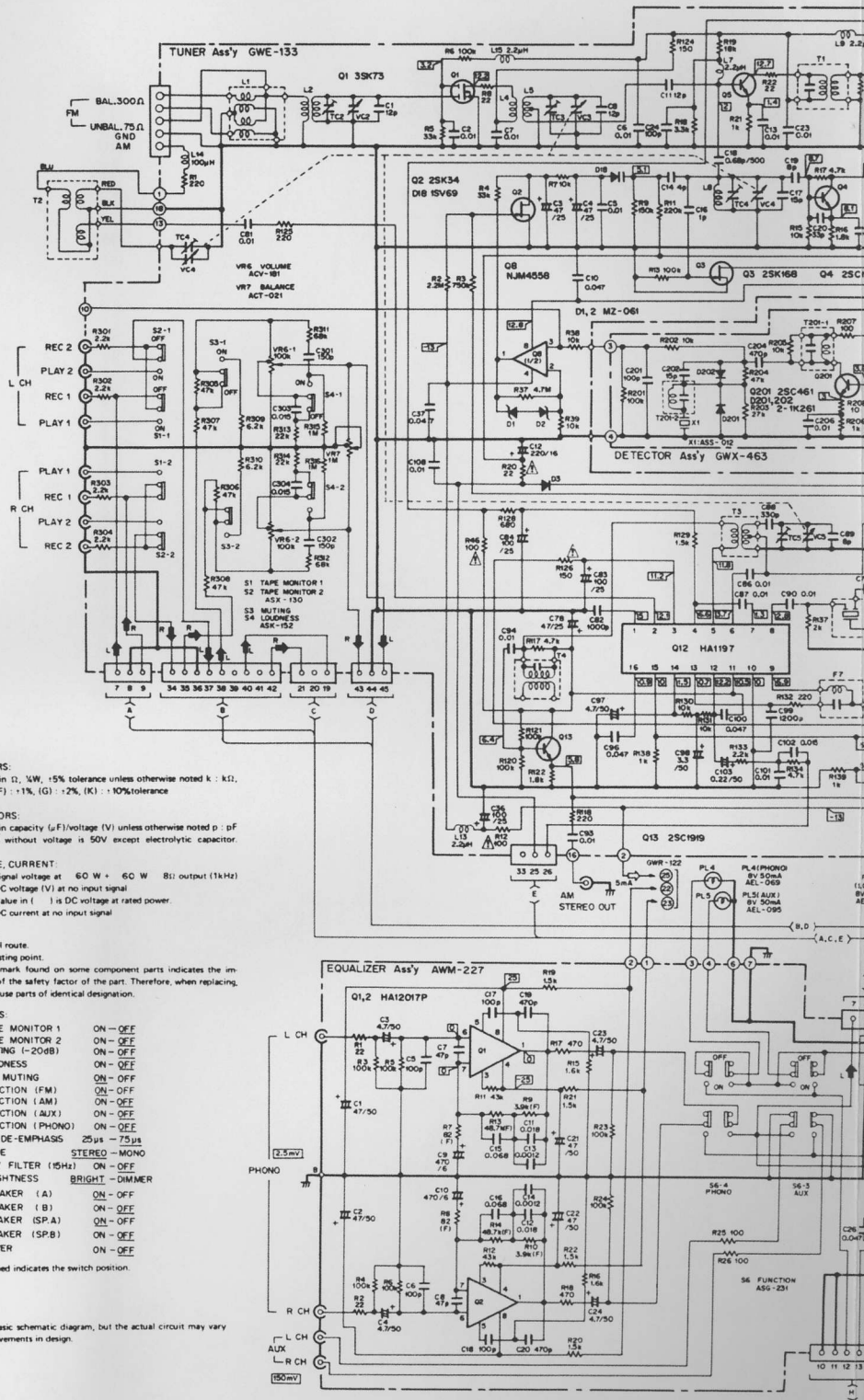

1. RESISTORS:
Indicated in Ω , $k\Omega$, 5% tolerance unless otherwise noted; k: k Ω , M: M Ω , (F): 1%, (G): 2%, (K): 10% tolerance
2. CAPACITORS:
Indicated in capacity (pF)/voltage (V) unless otherwise noted; p: pF
Indication without voltage is 50V except electrolytic capacitor.
3. VOLTAGE, CURRENT:

∇	Signal voltage at 60 W + 60 W B1 output (1kHz)
\square	DC voltage (V) at no input signal
\square	Value in () is DC voltage at rated power.
\leftarrow	mA DC current at no input signal
4. OTHERS:
 - \bullet Signal route.
 - \odot Adjusting point.

The Δ mark found on some component parts indicates the importance of the safety factor of the part. Therefore, when replacing, be sure to use parts of identical designation.

SWITCHES:

S1: TAPE MONITOR 1	ON - OFF
S2: TAPE MONITOR 2	ON - OFF
S3: MUTING (-20dB)	ON - OFF
S4: LOUDNESS	ON - OFF
S5: FM MUTING	ON - OFF
S6-1: FUNCTION (FM)	ON - OFF
S6-2: FUNCTION (AM)	ON - OFF
S6-3: FUNCTION (AUX)	ON - OFF
S6-4: FUNCTION (PHONO)	ON - OFF
S7: FM DE-EMPHASIS	25 μ s - 75 μ s
S8: MODE	STEREO - MONO
S9: LOW FILTER (15Hz)	ON - OFF
S10: BRIGHTNESS	BRIGHT - DIMMER
S11: SPEAKER (A)	ON - OFF
S12: SPEAKER (B)	ON - OFF
S13-1: SPEAKER (SP.A)	ON - OFF
S13-2: SPEAKER (SP.B)	ON - OFF
S14: POWER	ON - OFF

The underlined indicates the switch position.

This is the basic schematic diagram, but the actual circuit may vary due to improvements in design.

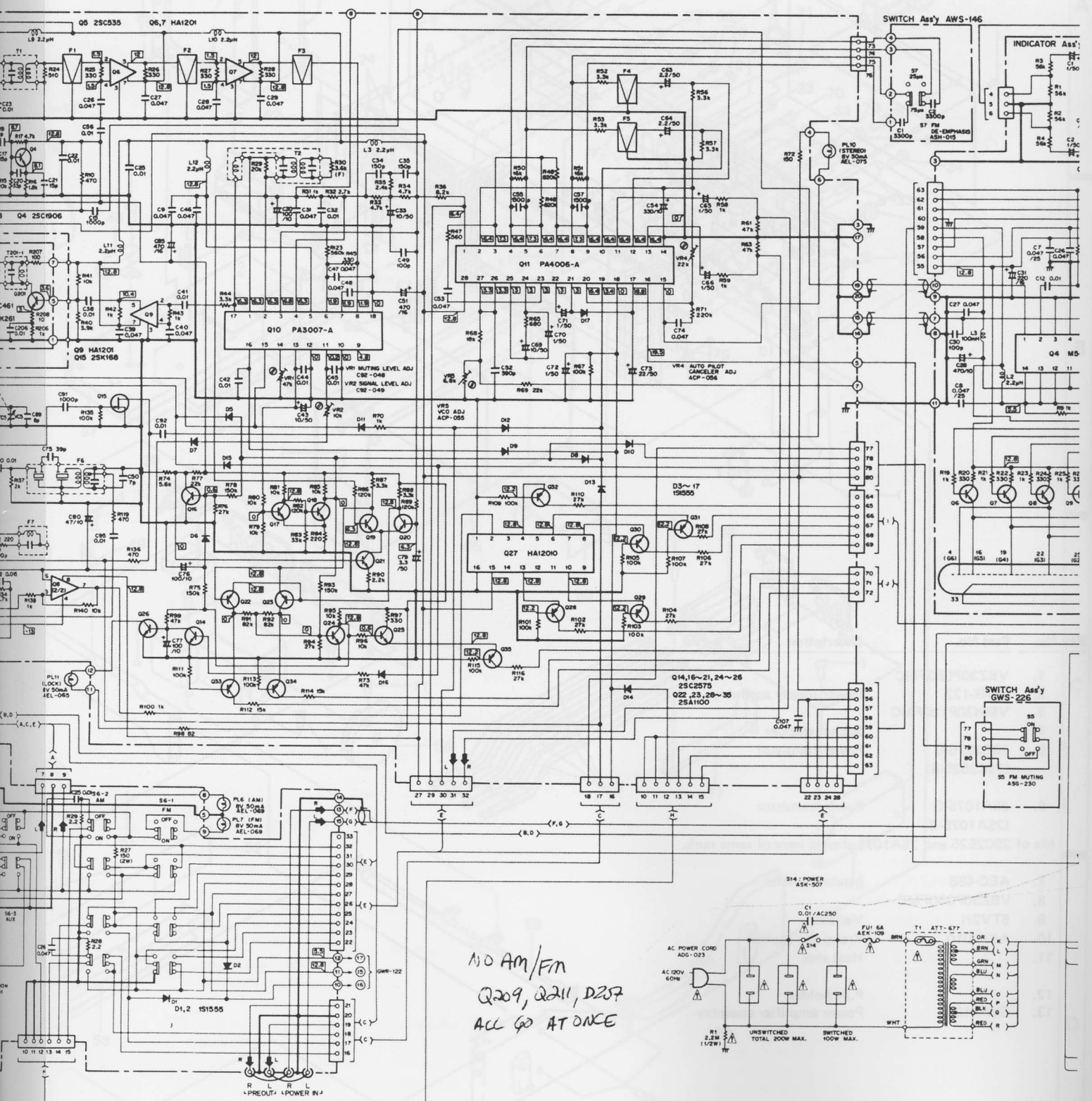

NO AM/FM
 Q209, Q211, D207
 ALL GO AT ONCE

Ass'y AWS-146

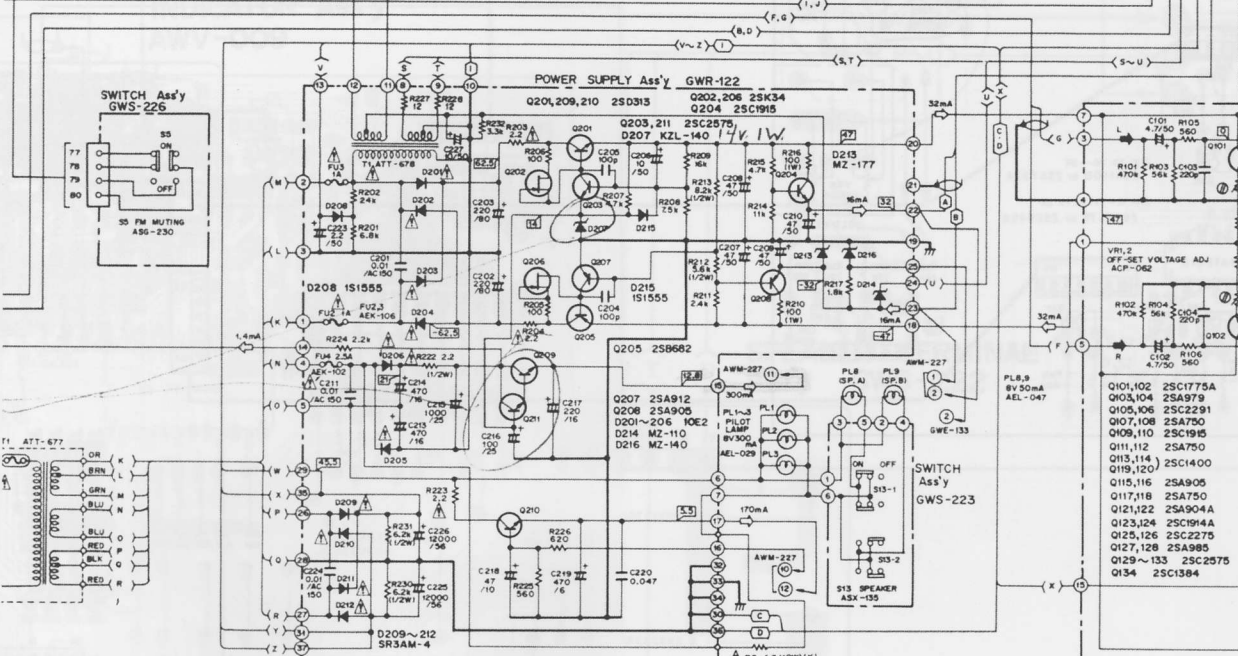
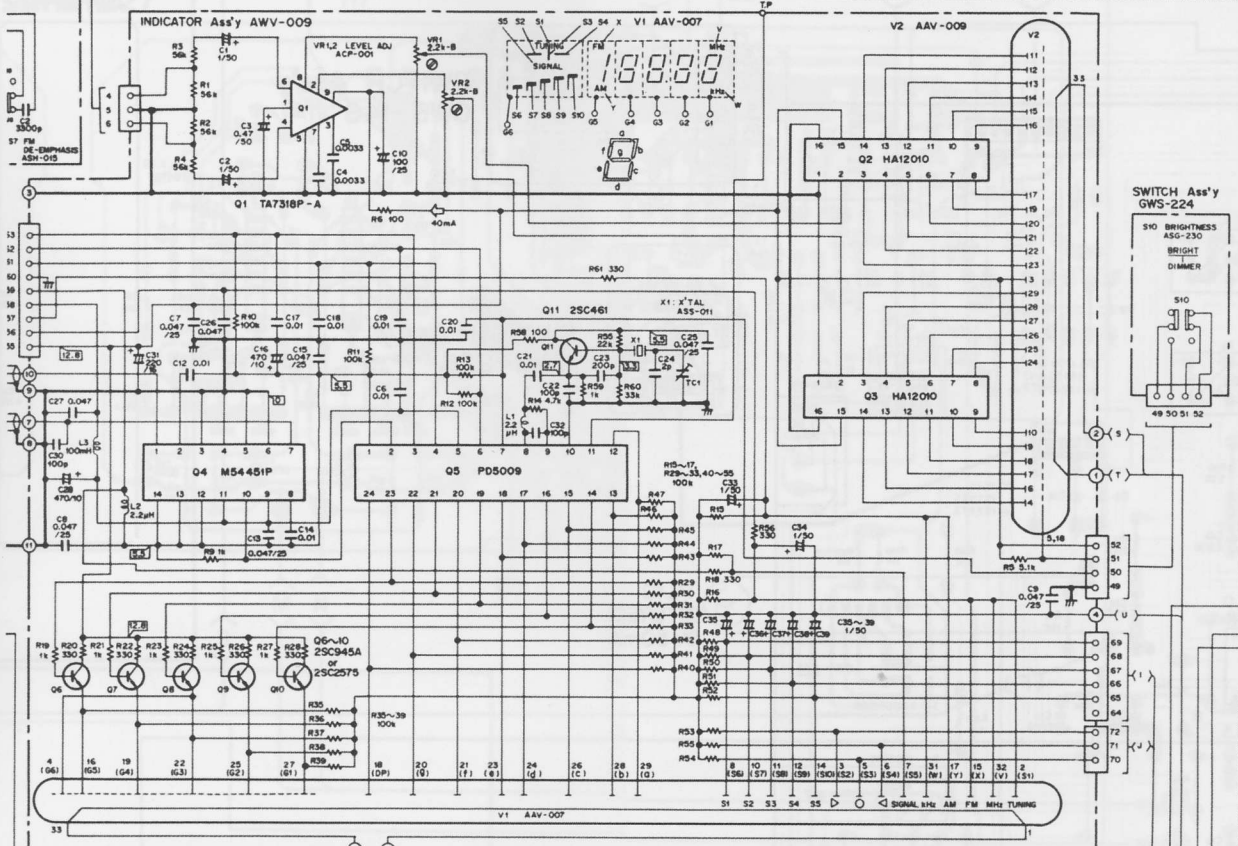

10

11

12

NOTE:
The indicated semiconductors are representative ones only. Other alternative semiconductors may be used and are listed in the parts list.

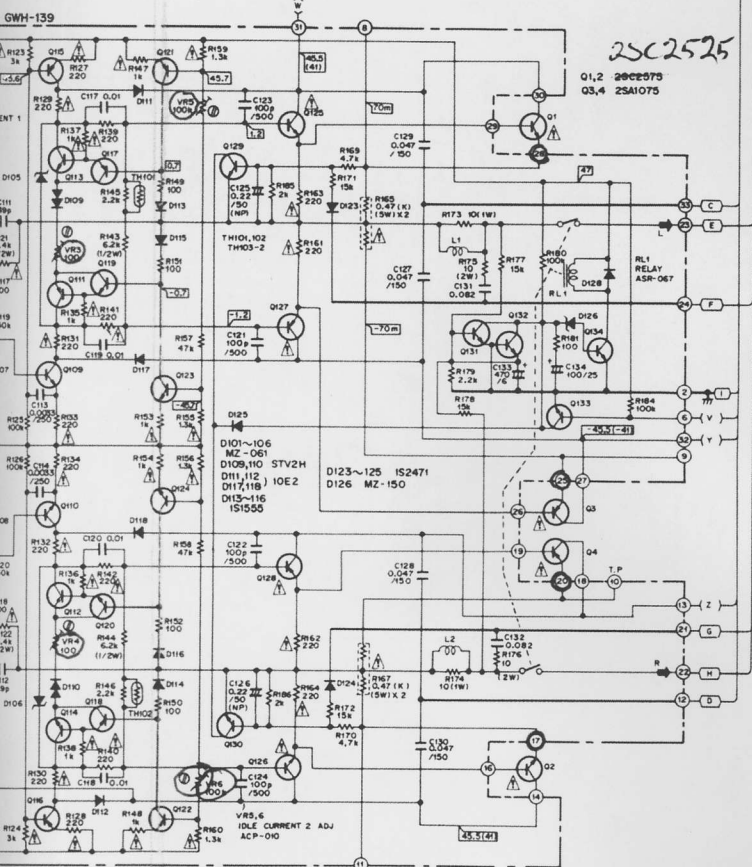
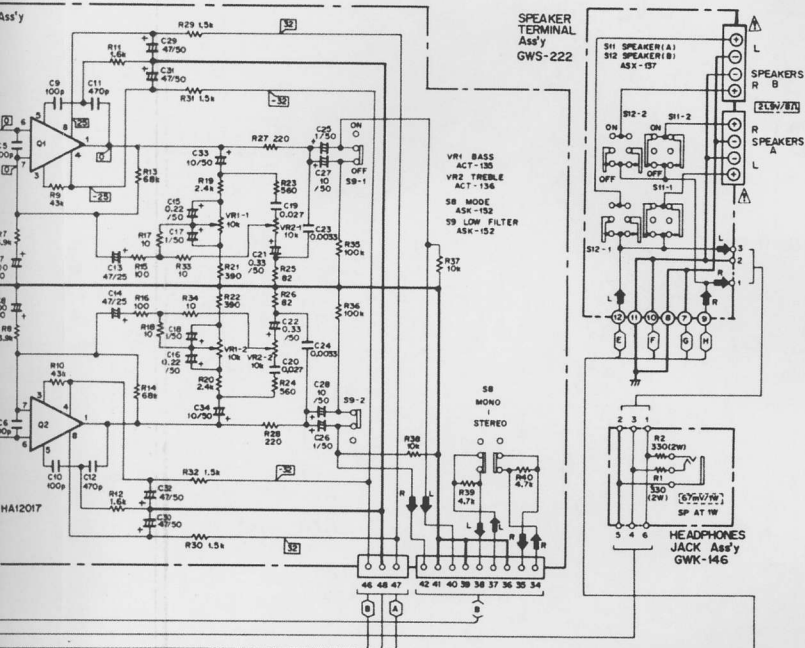

A

B

C

D

10

11

12

Top View

Speaker terminal assembly
GWS-222

⚠ Fuse 6A
AEK-109

⚠ Power transformer
ATT-677

Power supply assembly
GWR-122

⚠ Resistor (4.7/10W)
ACN-115

Equalizer assembly
AWM-227

Tuner assembly
GWE-133

Power amplifier assembly
GWH-139

FL indicator assembly
AWV-009

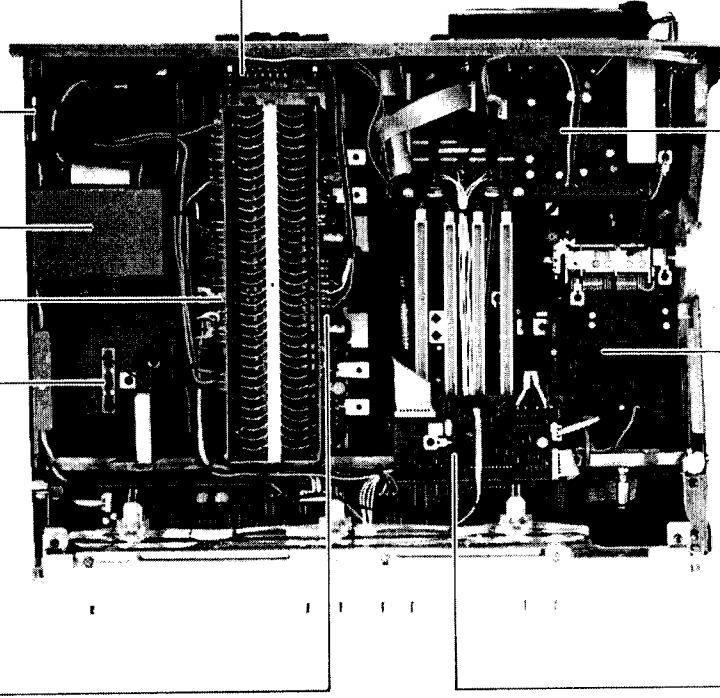

Bottom View

Power amplifier assembly
GWH-139

Tuner assembly
GWE-133

Power supply assembly
GWR-122

Headphones jack assembly
GWK-146

Tone control assembly
GWG-141

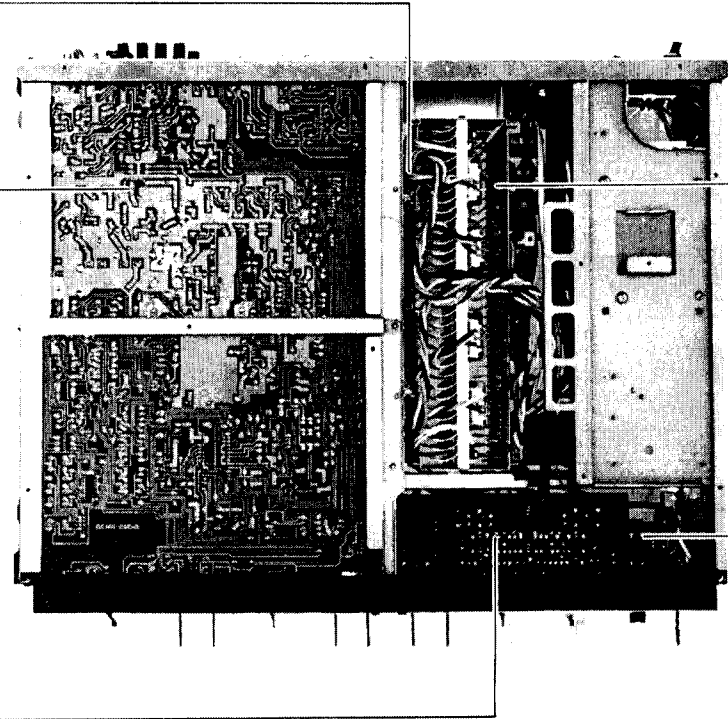

7. DIAL CORD STRINGING

1. Remove the bonnet case and front panel as described in the "Disassembly" section on page 16.
2. Remove the tuning drum from the shaft of the tuning capacitor.
3. Tie one end of the cord to the stud ① located inside the tuning drum.
4. Rotate the tuning capacitor right around until the rotor blades are fully intermeshed.
5. Secure the tuning drum back onto the tuning capacitor shaft, making sure that the securing screw ② faces directly upward.
6. Pass the cord out through the small opening in the circumference of the tuning drum (see diagram), and then take it over pulleys A, B, C, D, and E in that sequence.
7. Wind the cord around the dial shaft 3 times.
8. Pass it over pulley F, wind it around the tuning drum 2 times, and finally tie it to the spring hook ③ so that it is tensioned.
9. Turn the dial shaft, and check that the cord moves smoothly.
10. Cut off any excess cord.
11. Turn the dial shaft counter-clockwise as far as it will go.
12. Align the dial pointer with the starting point of the dial scale, and then pass the cord over it.
13. Check that the dial pointer is in line with the starting point of the dial scale.
14. Finally apply the locking paint to the cord securing positions (stud ① and spring hook ③) and the dial pointer connection.

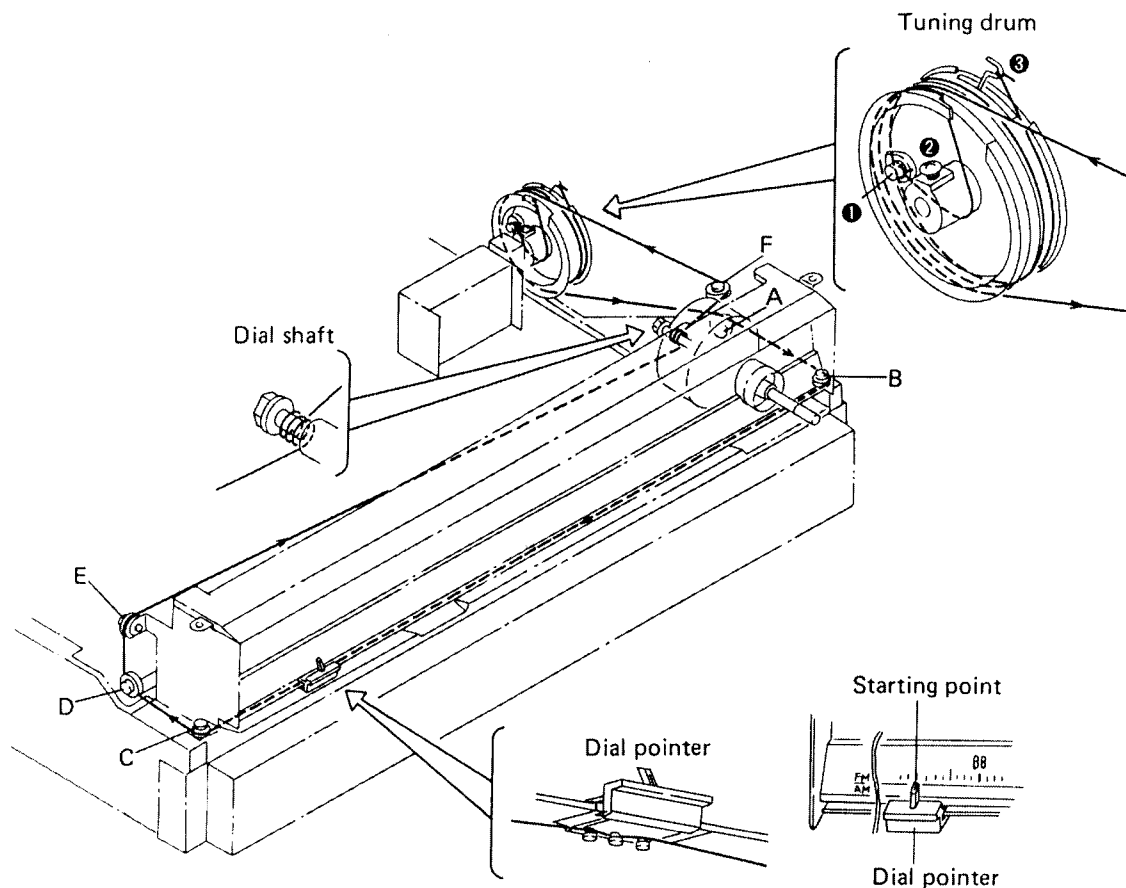

8. ADJUSTMENTS

8.1 FM TUNER

FM Tracking

- Connect the SIGNAL meter or DC voltmeter between R100 (no.7 pin of Q8) on the tuner assembly and ground.
- The tuning coil in the RF amplifier circuit does not have an adjusting core. Consequently, tracking adjustment at 90MHz are performed by regulating the gap between rotor and stator of the tuning capacitor (VC3). The expression "adjust VC" found in the text means that the two outer rotor blades of each of these tuning capacitors are to be extended outwards with spatula (Part No.GGK-066) as shown in Fig. 8-1.

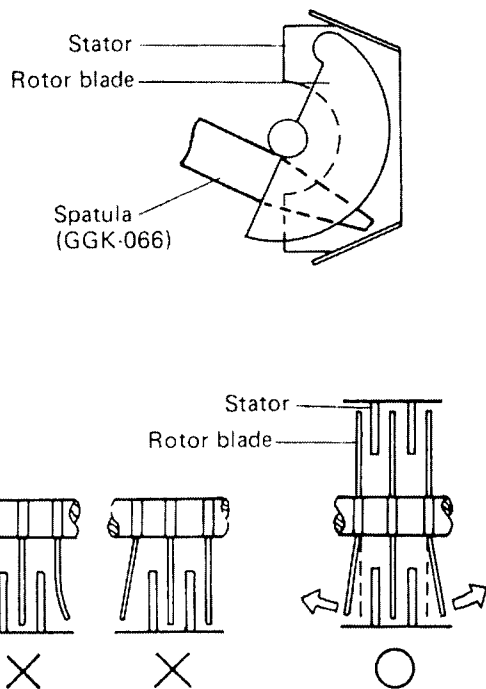

Fig. 8-1 Adjustment of tuning capacitor

1. Set up the test equipment as Fig. 8-2.
2. Set the FM MUTING switch to OFF, and FUNCTION switch to FM.
3. Tune the SX-3800 dial pointer to 106MHz, and set the FM SG (FM signal generator) output frequency to 106MHz, output level to 60dB, modulation frequency 400Hz, frequency deviation 75kHz (100% modulation).
4. Adjust the TC1 (OSC trimmer) to obtain maximum deflection of the signal meter.
5. Then tune the dial pointer to 90MHz, and set the FM SG output frequency to 90MHz.
6. Adjust the core of L8 (OSC coil) to obtain maximum deflection of the signal meter.
7. Repeat steps 3 — 6 above.

8. Set the FM SG output level to 20 — 30dB, and adjust TC2 (ANT trimmer) and TC3 (RF trimmer) at 106MHz, and L2 (ANT coil) and VC3 (RF tuning capacitor) at 90MHz in the same manner as described above in steps 3 — 7. These adjustments will ensure optimum sensitivity in the 90MHz — 106MHz range, and minimum difference in sensitivity between the two extreme frequencies.
9. Retune the dial pointer to a position with no input signal.
10. Adjust the N core of T2 so that the voltage between no. 8 and no.9 terminals on the tuner assembly is reduced to DC 0V.
11. Set the FM SG output level to 60dB and output frequency to 98MHz, and fine tune the SX-3800 to this position.
12. Then rotate the D core of T2 to obtain minimum distortion in the demodulated output (REC terminal) to minimum.
13. Repeat steps 9 — 12 above until both requirements are satisfied.
14. Reset the step 11 again.
15. Adjust the VR2 so that the 5-point SIGNAL indicator reads 5.
16. Set the FM SG output level to 20dB, and turn the FM MUTING switch to ON.
17. Adjust the VR1 to the point where the muting is operated.

Multiplex Decoder

- Connect the MPX SG (FM multiplex generator) to the external modulator terminals of FM SG, thereby using FM SG as external modulation.
1. Set the FM SG output frequency to 98MHz, output level to 60dB (unmodulated), and tune the SX-3800 to this frequency.
 2. Adjust the VR5 to obtain a 76kHz signal at no.7 terminal on the tuner assembly.
 3. Set the MPX SG modulation output to pilot signal (19kHz) only, and set the FM deviation of 7.5kHz (10% modulation).
 4. Adjust the VR4 to obtain minimum leakage of the 19kHz pilot signal at the REC terminal.
 5. Raise the FM SG output level to 80dB, and set the MPX SG to Main 1kHz (L+R), 67.5kHz deviation (90% modulation), and pilot signal to 7.5kHz deviation (10% modulation).
 6. Adjust the T1 core to within $\pm 90^\circ$ to obtain minimum distortion in the demodulated output (REC terminal).

Crystal Detector

1. Set the FM SG output frequency to 98MHz output level to 60dB (unmodulated), and tune the SX-3800 to this frequency.
2. Adjust the B core of T201 so that the voltage between no.10 terminal of the tuner assembly and ground is reduced to DC 0V ($\pm 300mV$).
3. Set the FM SG output level to 60dB, modulation frequency 400Hz, frequency deviation 75kHz (100% modulation).
4. Adjust the A core of T201 to obtain maximum AC voltage reading between no.10 terminal of the tuner assembly and ground.

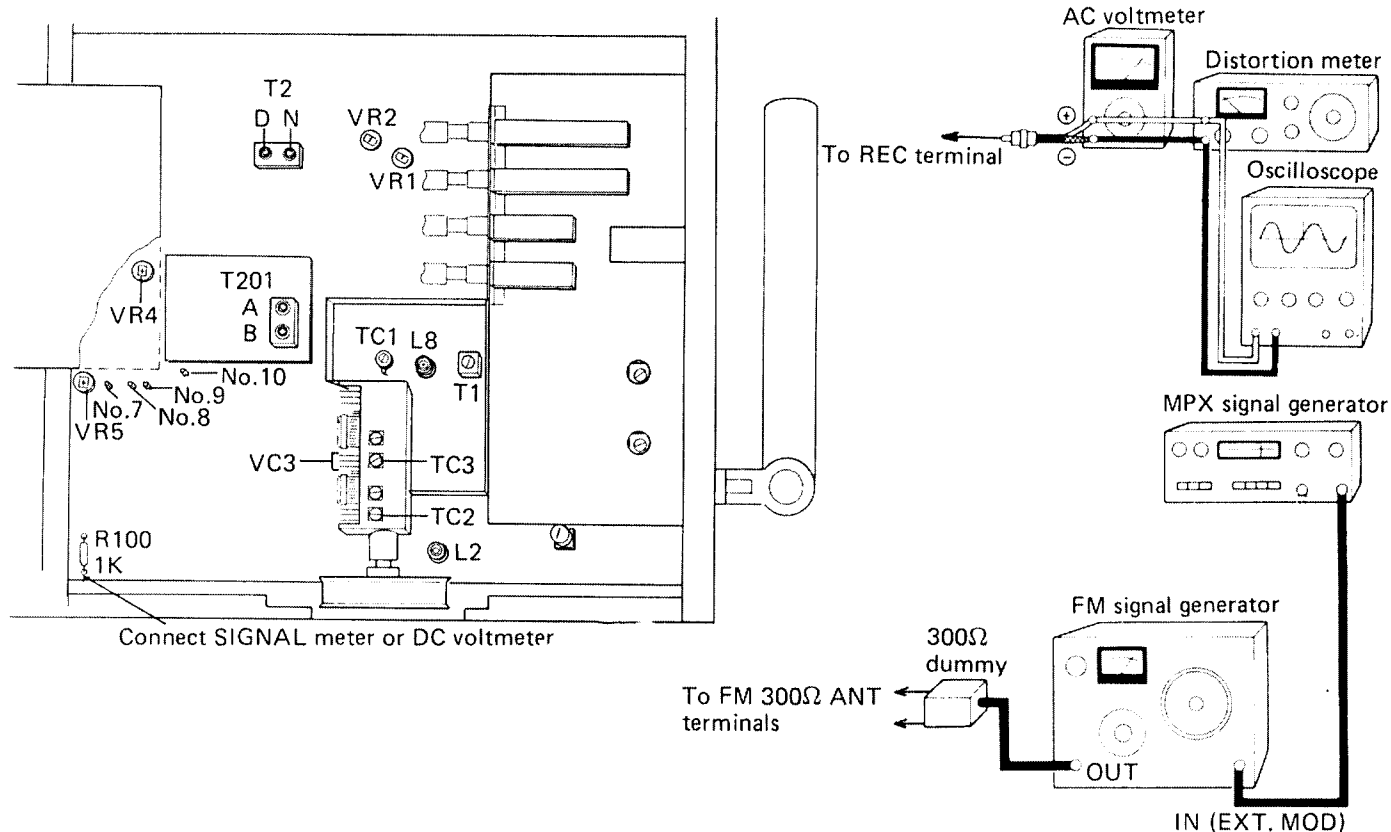

Fig. 8-2

8.2 AM TUNER

1. Set up the test equipment as Fig. 8-3.
2. Set the FUNCTION switch to AM.
3. Tune the SX-3800's dial pointer to 600kHz, and the AM SG (AM signal generator) output frequency to 600kHz, modulation frequency of 400Hz, 30% modulated and output level of 30dB - 100dB.
4. Adjust the core of T3 to obtain maximum output level (REC terminal).
5. Then tune to 1400kHz and also set the AM SG output frequency to 1400kHz.
6. This time adjust TC5 to obtain maximum output level (REC terminal).
7. Repeat steps 3 - 6 above.
8. Set the AM SG output level to about 30dB, adjust the coil along the bar antenna and T3 at 600kHz, and TC4 and TC5 at 1400kHz, in the same manner as described in the above steps. This is the adjustment for optimum sensitivity across the frequency band, and minimum difference in sensitivity at different frequencies.
9. Reset the AM SG output frequency to 1400kHz, and also tune the SX-3800 to this frequency.
10. Adjust the cores of T4 and F7 to obtain maximum output level (REC terminal).

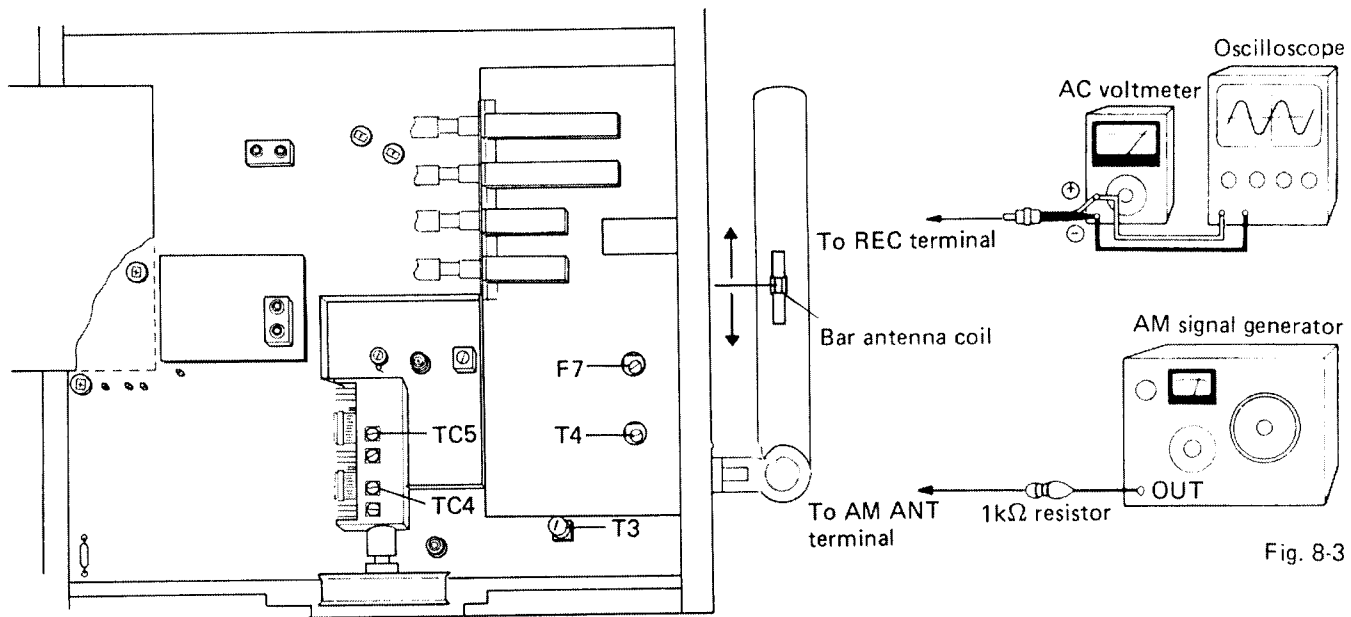

Fig. 8-3

8.3 POWER AMPLIFIER

Turn VR3, VR5(L) and VR4, VR6(R) fully around in the counter-clockwise direction, but set VR1(L) and VR2(R) to the center positions. Without any load or input signal, turn the POWER switch ON.

DC Balance

1. Adjust VR1(L) for 0V (to within $\pm 30\text{mV}$) between terminal no.23 and ground.
2. Adjust VR2(R) for 0V (to within $\pm 30\text{mV}$) between terminal no.22 and ground.

Idle Current

1. Adjust VR3(L) for 120mV between terminals no.28(+) and no.25(-).
2. Adjust VR4(R) for 120mV between terminals no.17(+) and no.20(-).
3. Adjust VR5(L) for 150mV between terminals no.28 and no.25.
4. Adjust VR6(R) for 150mV between terminals no.17 and no.20.

*Adjustment must be done in or near horizontal (normal) operating position for correct cooling flow and positive thermal tracking.
(in upside down)*

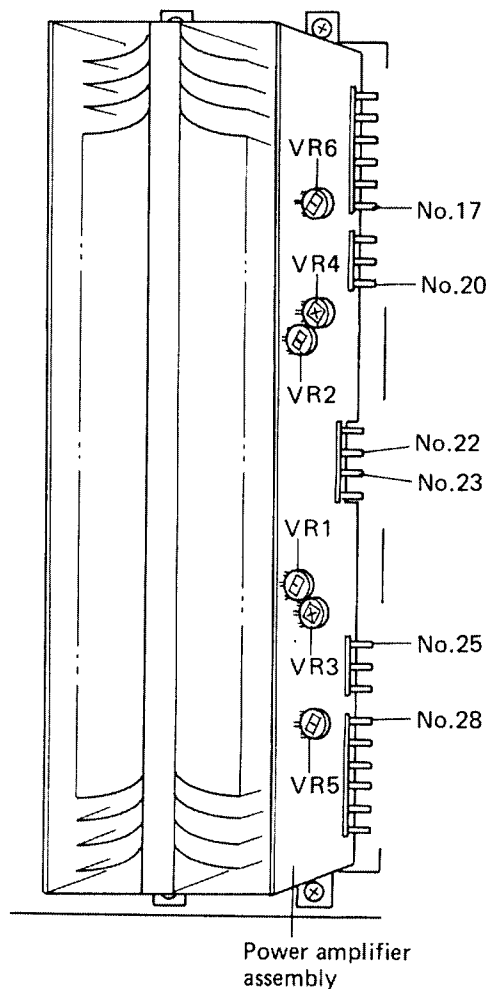

Fig. 8-4

8.4 FL INDICATOR CIRCUIT

Frequency Display Circuit

- The counter IC (PD5009) has been designed to match FM ceramic filter IF offset (caused by displacement of the central frequency) by combination of the inputs (of H or L level) applied to pin nos.3 & 4. The matching IF offset in the SX-3800 is determined according to the combinations of connections and disconnections between the R 28 and R 28 resistors in the equalizer assembly (AWM-227). Check that the combinations shown in the table below have followed for the corresponding grades of FM ceramic filters F1 ~ F3 (3 ranks — color coded).

FM ceramic filter (F1—F3)	PD5009		AWM-227	
	Pin no.3	Pin no.4	R28(2.2Ω)	R29(2.2Ω)
Red	L	H	Cut	Connect
Blue	H	H	Cut	Cut
Orange	H	L	Connect	Cut

H ≅ 5.5V, L ≅ 0V

- If the SX-3800 frequency display reads 97.95MHz or 98.05MHz when a 98.00MHz signal is applied to the receiver, adjust TC1 so that the display reads 98.00MHz correctly.
- If an accurate 98.00MHz input signal source is not available, tune the receiver to the nearest known broadcasting station in the 98MHz region, and check that the station's frequency is correctly displayed, adjusting TC1 if necessary.

Output Power Indicator Calibration

- Apply a 1kHz signal to the POWER AMP IN terminals.
- Adjust the level of this input signal so that the voltage on the output terminals (SPEAKERS) read 8.95V (AC).
- Adjust VR1(L) and VR2(R) so that the output power indicator read 10 watts.

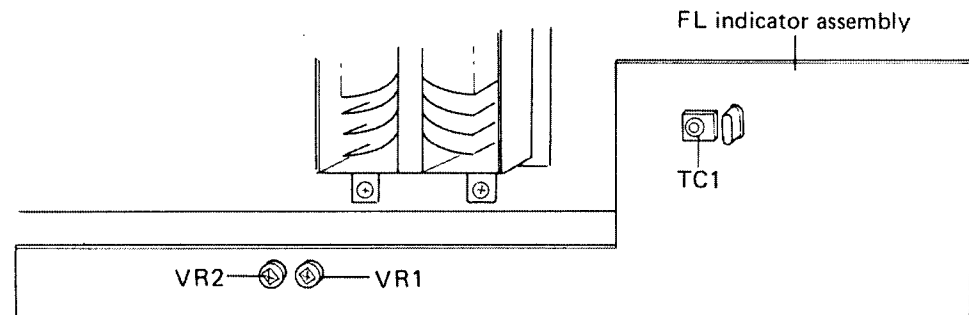
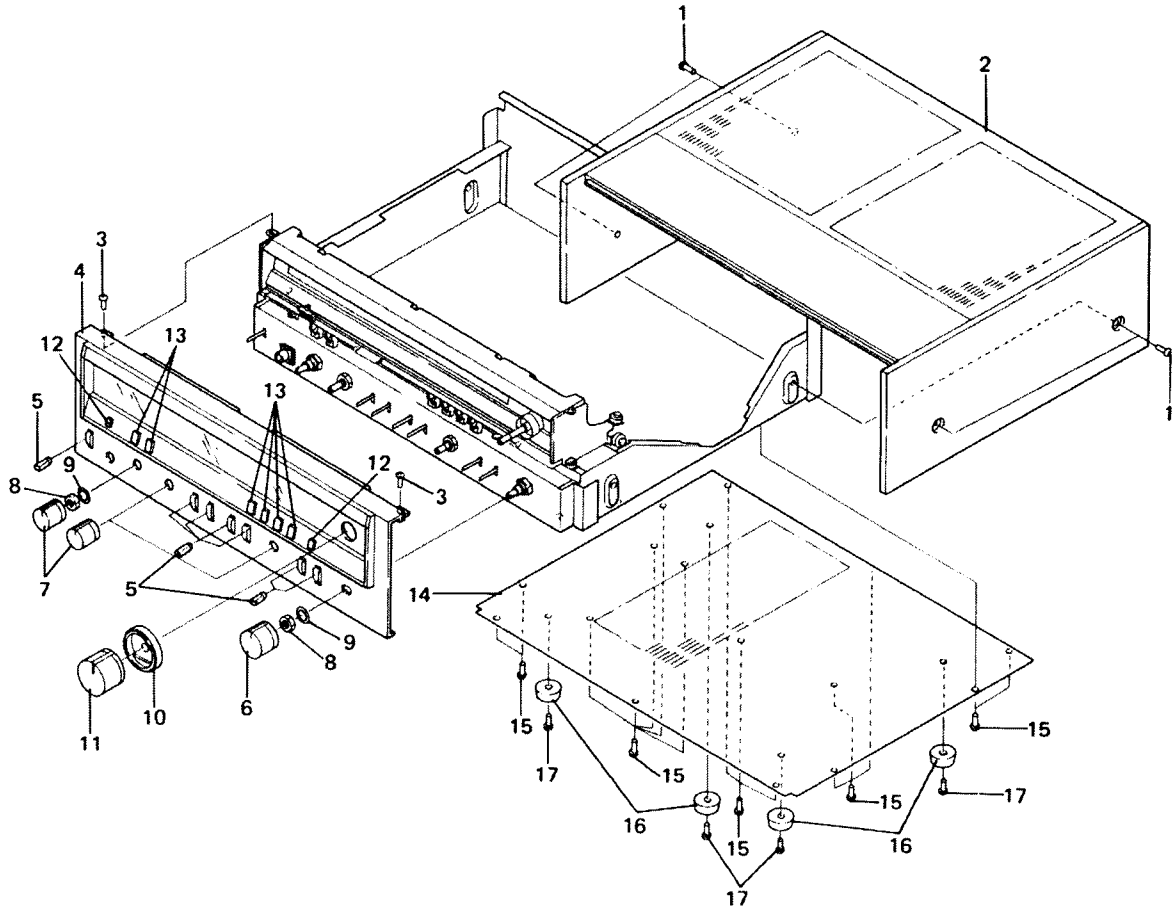

Fig. 8-5

9. EXPLODED VIEW

Exterior Components











Key No.	Part No.	Description
1.	DCK40P150FZK	
2.	AMM-086	Bonnet case
3.	VBZ30P080FMC	Front panel assembly
4.	ANB-851	Lever knob
5.	AAD-139	
6.	AAB-240	Knob
7.	AAB-239	Knob
8.	NK90UC	
9.	WA92F140U100	
10.		Hood
11.	AAA-066	Knob
12.	AAD-227	Push knob B
13.	AAD-226	Push knob A
14.		Bottom plate
15.	VBZ30P080FMC	
16.	AEC-178	Foot assembly
17.	VTZ40P120FMC	

Interior Components

NOTES:

- Parts without part number cannot be supplied.
- The  mark found on some component parts indicates the importance of the safety factor of the part. Therefore, when replacing, be sure to use parts of identical designation.

Key No.	Part No.	Description	Key No.	Part No.	Description
1.	VBZ30P060FMC		46.		Lamp holder
2.		Pulley assembly	47.		Dial scale holder R
3.		Pulley assembly (small)	48.		Capacitor holder
4.		Dial scale holder L	49.		Ground terminal 2P
5.		Side plate	50.		Center channel
6.	PMZ30P060FMC		51.	GWE-133	Tuner assembly
7.		Dial panel assembly	52.		Shield plate
8.		Smoother	53.		Center frame
9.		Dial pointer	 54.	ATT-677	Power transformer
 10.	AEK-109	Fuse 6A	 55.	AKP-042	AC socket (AC OUTLETS)
11.	VBZ40P080FMC		56.	AXA-264	Dial shaft assembly
12.	AKR-032	Fuse holder	57.		Transformer holder
13.	AEL-065	Lamp with wire (8V, 50mA)	58.		Tuning drum assembly
14.		Side frame L	59.		Ground frame
15.	WA92F140U100		60.		Side frame (R)
16.	NK90FUC		61.		Raer panel
17.		Shaft cover A	62.	GWS-222	Speaker terminal assembly
18.	GWK-146	Headphones jack assembly	 63.	AEK-102	Fuse 2.5A
 19.	ACG-001	Ceramic capacitor (0.01/250V)	 64.	AEK-106	Fuse 1A
 20.	ASK-507	Lever switch (POWER)	65.		Heat sink block
21.	GWS-223	Switch assembly	66.		Heat sink holder
22.	GWS-224	Switch assembly	67.		Rod
23.	AEL-047	Lamp with wire (8V, 50mA)	68.	AEC-327	Strain relief
24.		Remote wire	69.	MTX30P100FZK	
25.	GWG-141	Tone control assembly	70.	BBZ30P080FZK	
26.		Remote wire	71.	ABA-176	Screw 3x10x9R
27.	ASX-128	Remote lever switch	 72.	ADG-023	AC power cord
28.	AEL-069	Lamp with wire (8V, 50mA)	73.	ATB-624	Bar-antenna assembly
29.	AEL-095	Lamp with wire (8V, 50mA)	74.		Terminal (GND)
30.	GWS-226	Switch assembly	75.	GWS-226	Switch assembly
31.		Panel frame	76.	AKB-076	Terminal (AM STEREO OUT)
32.		Spacer A	77.		EQ holder A
33.	BBT30P080FZK		78.	AWM-227	Equalizer assembly
34.	PMT30P060FZK		79.		EQ holder B
35.		Spacer B	80.	WA35F100N080	
36.		Mounting plate	81.	AKM-004	Jumper plug
37.	ABN-050	Union nut			
38.	ABE-001	Internal toothed lock washer			
39.	BBT30P060FZK				
40.		Acrylic board			
41.	AEL-029	Lamp (wedge type 8V, 300mA)			
42.	AKK-005	Lamp socket			
 43.	ACN-115	Resistor (4.7/10W)			
44.	AWV-009	FL indicator assembly			
45.	AEL-075	Lamp with wire (8V, 50mA)			

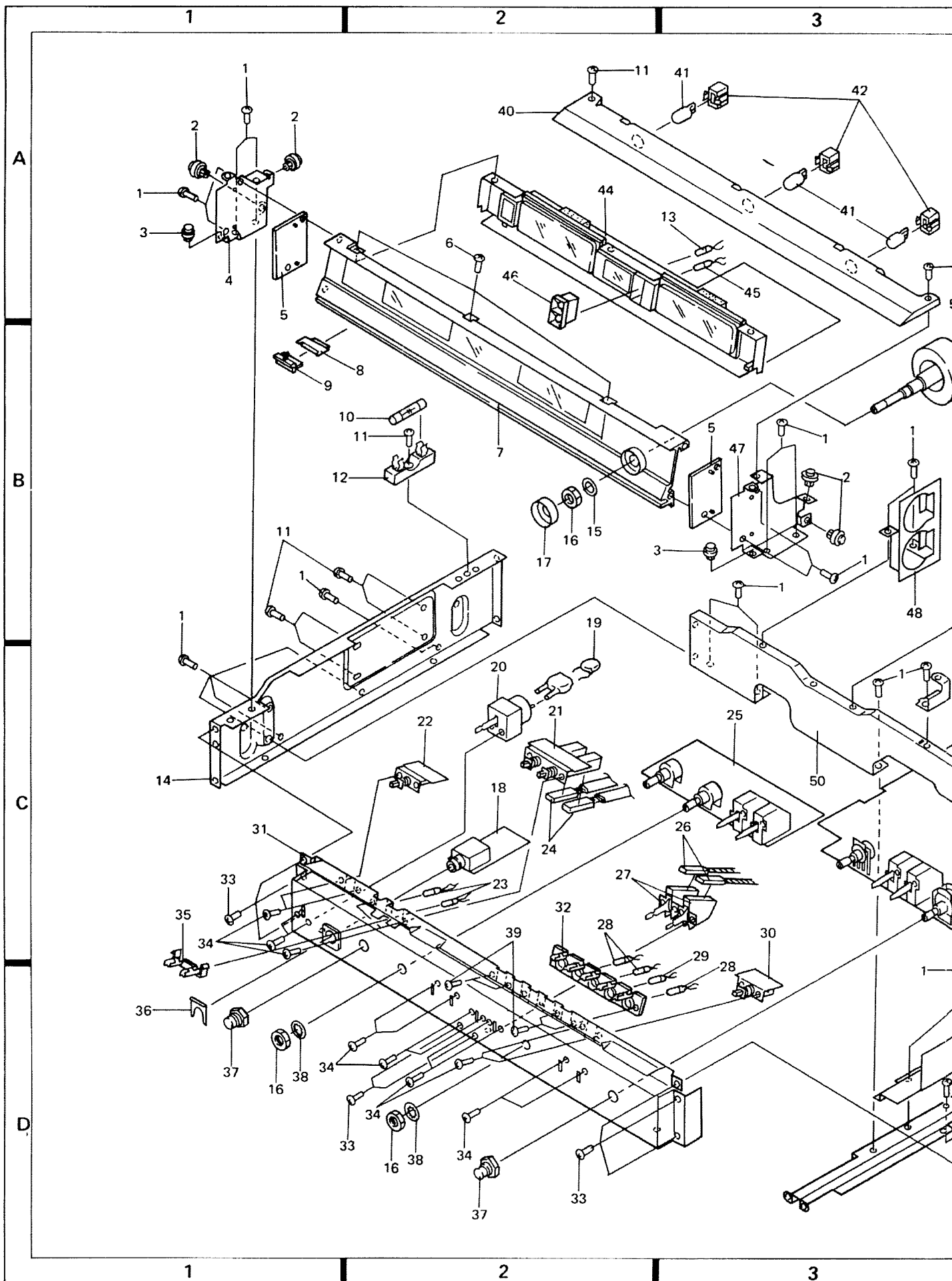

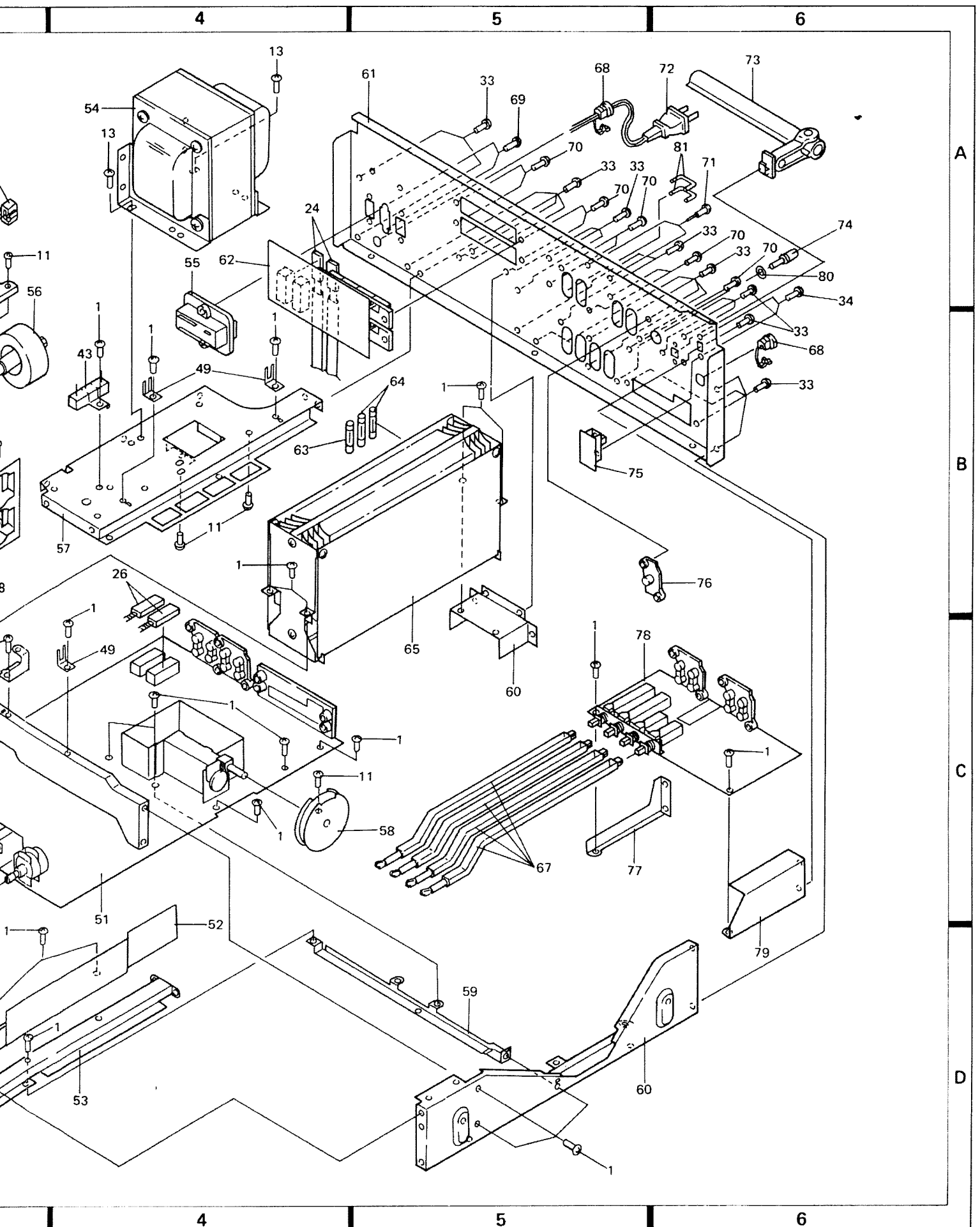

A

B

C

D

4

5

6

Heat Sink Block

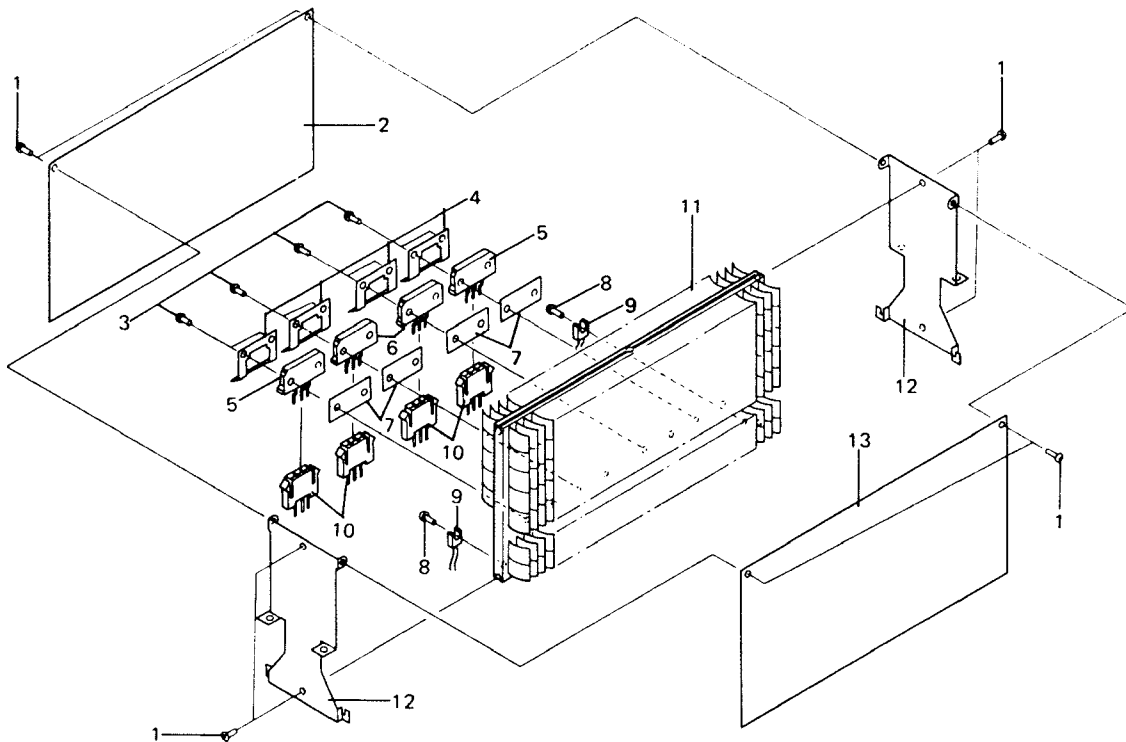

Key No.	Part No.	Description
1.	VBZ30P060FMC	
2.	GWR-122	Power supply assembly
3.	VMH30P120FMC	
4.		Socket stopper
5.	2SC2525-G (2SC2525-B)	Power transistor
6.	2SA1075-G (2SA1075-B)	Power transistor
Note: hfe of 2SC2525 and 2SA1075 should have of same rank.		
7.	AEC-488	Insulator wafer
8.	VBZ30P080FMC	
9.	STV2H	Varistor
10.	AKH-010	Transistor socket
11.		Heat sink
12.		P.A. holder
13.	GWH-139	Power amplifier assembly

10. SCHEMATIC DIAGRAMS, P.C. BOARD CONNECTION DIAGRAM AND PARTS LIST

External Appearance of Transistors and ICs

2SA979

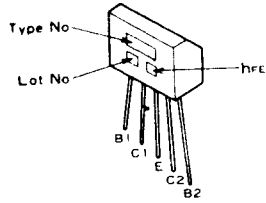

**2SA1100
2SC1919
2SC2575**

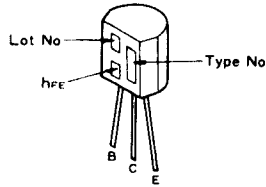

**2SA750
2SC1400
2SC945A**

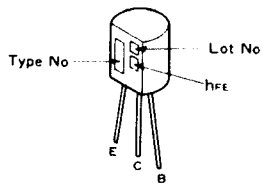

**2SA1075
2SC2525**

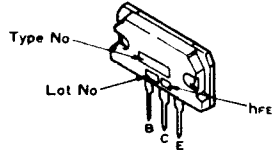

**2SA904A
2SC1914A**

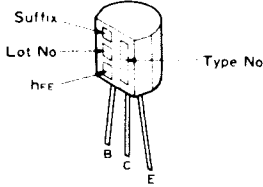

**2SA733A
2SC1775A**

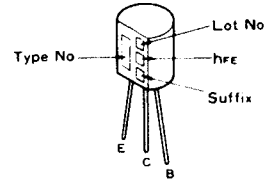

**2SA905
2SC1915**

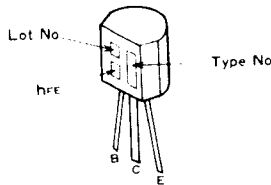

2SB682

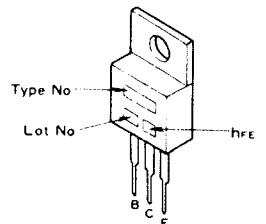

**2SA985
2SC2275**

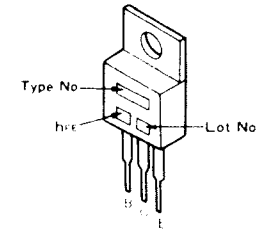

2SC2291

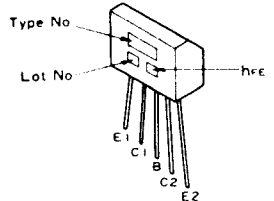

2SA726S

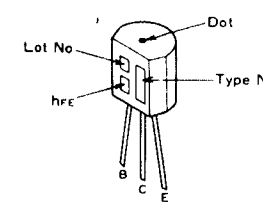

2SC1384

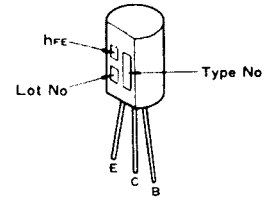

**2SC461
2SC535**

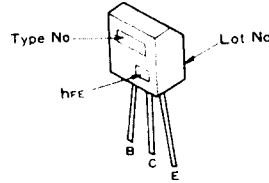

**HA12010
HA1197**

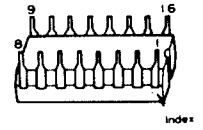

2SC1906

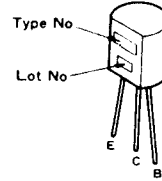

**HA1201
NJM4558DV**

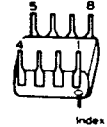

2SD313

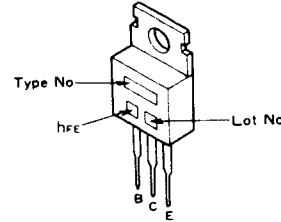

TA7318P-A

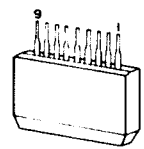

2SK34

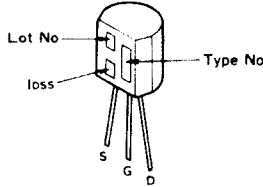

PA3007-A

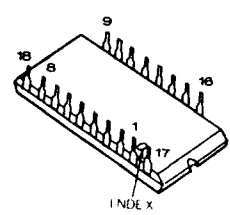

2SK168

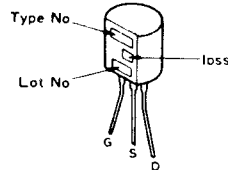

PA4006-A

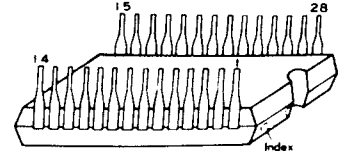

3SK73

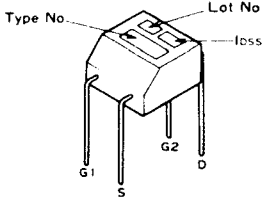

HA12017P

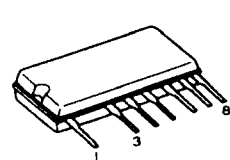

M54451P

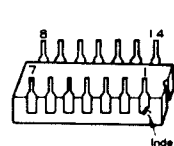

PD5009

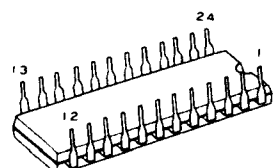

10.3 PARTS LIST

NOTES:

- When ordering resistors, first convert resistance values into code form as shown in the following examples.

Ex. 1 When there are 2 effective digits (any digit apart from 0), such as 560 ohm and 47k ohm (tolerance is shown by J = 5%, and K = 10%).

560Ω 56 × 10¹ 561 RD¼PS 561J
 47kΩ 47 × 10³ 473 RD¼PS 473J
 0.5Ω 0R5 RN2H 0R5K
 1Ω 010 RSIP 010K

Ex. 2 When there are 3 effective digits (such as in high precision metal film resistors).

5.62kΩ 562 × 10¹ 5621 RN¼SR 5621F

- The Δ mark found on some component parts indicates the importance of the safety factor of the part. Therefore, when replacing, be sure to use parts of identical designation.

Miscellaneous Parts

ELECTRO-PARTS

Part No.	Symbol & Description
Δ ATT-677	T1 Power transformer
ATB-624	T2 Bar-antenna assembly
AEL-029	PL1-PL3 Lamp (wedge type)
AEL-069	PL4, PL6, PL7 Lamp with wire
AEL-095	PL5 Lamp with wire (8V, 50mA)
AEL-047	PL8, PL9 Lamp with wire (8V, 50mA)
AEL-075	PL10 Lamp with wire (8V, 50mA)
AEL-065	PL11 Lamp with wire (8V, 50mA)
Δ AEK-109	FU1 Fuse (6A)
Δ AEK-106	FU2, FU3 Fuse (1A)
Δ AEK-102	FU4 Fuse (1.5A)
Δ 2SC2525-G* (2SC2525-B*)	Q1, Q2
Δ 2SA1075-G* (2SA1075-B*)	Q3, Q4
*hfe of Q1-Q4 should have the same rank.	
Δ ASK-507	S1 Lever switch (POWER)
Δ ACG-001	C1 Ceramic capacitor (0.01/250V)
Δ ACN-029	R1 Resistor (2.2M)
ACN-115	R2 Resistor (4.7/10W)
Δ ADG-023	AC power cord
Δ AKP-042	AC socket (AC OUTLETS)
AKR-032	Fuse holder
AKB-076	Terminal (AM STEREO OUT)
CEA 100M 50L	C2

P.C. BOARD ASSEMBLIES

Part No.	Description
GWE-133	Tuner assembly
AWS-146	Switch assembly
GWH-139	Power amplifier assembly
GWR-122	Power supply assembly
GWS-226	Switch assembly
GWX-463	Detector assembly
GWG-141	Tone control assembly

Part No.	Symbol & Description
GWS-224	Switch assembly
AWM-227	Equalizer assembly
GWS-222	Speaker terminal assembly
GWS-223	Switch assembly
GWK-146	Headphones jack assembly
AWV-009	FL indicator assembly

Tuner Assembly (GWE-133)

CAPACITORS

Part No.	Symbol & Description
ACK-035	VC Tuning capacitor
ACM-006	TC1 Trimmer
CCDCH 070D 50	C50
CCDCH 010C 50	C16
CCDCH 040C 50	C14
CCDCH 120J 50	C11
CCDCH 150J 50	C21
CCDCH 330J 50	C20
ACG-018	C52 Ceramic (390P/50V)
CCDLH 080D 50	C19
CCDRH 150J 50	C17
CCDUJ 120J 50	C1, C8
CCDXL 080D 50	C89
CCDSL 390J 50	C75
CCDSL 101J 50	C24, C49
CCDSL 151J 50	C34, C35, C301, C302
CKDYB 102K 50	C82, C91, C15
CKDYB 122K 50	C99
CKDYF 103Z 50	C2, C5-C7, C13, C22, C23, C25, C32, C38, C41, C42, C44, C45, C81
CKDYF 103Z 50	C86, C87, C90, C92-C95, C101, C108
CKDYF 473Z 50	C9, C10, C26-C29, C31, C37, C39, C40, C46, C47, C48, C74
CKDYF 473Z 50	C96, C100, C107
CGB R68K 500	C18

Part No.	Symbol & Description
CKDYF 103Z 50	C56
CQMA 153K 50	C102
CQMA 473J 50	C53
CQSH 331J 50	C88
CQSH 152J 50	C55, C57
CEANL R22M 50	C103
CEANL 010M 50	C65, C66, C70, C71
CEANL 2R2M 50	C63, C64
CQMA 153K 50	C303, C304
CEA 010M 50L	C72
CEA 3R3M 50L	C79, C98
CEA 4R7M 50L	C97
CEA 100M 50L	C33, C43, C69
CEA 220M 25L	C73
CEA 470M 10L	C80
CEA 101M 10L	C30, C76, C77
CEA 101M 25L	C36, C83, C84
CEA 221M 16L	C12
CEA 331M 10L	C54
CEA 471M 16L	C51, C85
CEA 470M 25L	C3, C4, C78

Note: When ordering resistors, convert the resistance value into code form, and then rewrite the part no. as before.

RESISTORS

Part No.	Symbol & Description
RD $\frac{1}{2}$ PM $\square\square\square$ J	R1-R11, R13, R15-R19, R21, R22, R24-R29, R31-R45
RD $\frac{1}{2}$ PM $\square\square\square$ J	R47-R53, R56-R59, R61, R63, R65, R67-R99, R101-R125
RD $\frac{1}{2}$ PM $\square\square\square$ J	R128-R140, R301-R316
Δ RD $\frac{1}{2}$ PMF $\square\square\square$ J RN $\frac{1}{2}$ SQ $\square\square\square\square$ F	R12, R20, R46, R126 R30
C92-048	VR1 Semi-fixed 47k
C92-049	VR2 Semi-fixed 10k
ACP-056	VR4 Semi-fixed 22k
ACP-055	VR5 Semi-fixed 6.8k
ACV-181	VR6 Variable 100k (VOLUME)
ACT-021	VR7 Variable 1M (BALANCE)

TRANSFORMERS, COILS AND FILTERS

Part No.	Symbol & Description
ATE-008	T1 FM IFT
ATE-045	T2 FM DET transformer
ATB-063	T3 AM OSC coil
ATB-069	T4 AM IF coil
ATC-097	L2 FM antenna coil
T24-028	L3, L7, L9-L13, L15 RF coil
ATC-072	L8 FM OSC coil

Part No.	Symbol & Description
ATF-106*	F1-F3 FM ceramic filter
ATF-089	F4, F5 FM low-pass filter
ATF-105	F6 AM ceramic filter
ATF-038	F7 AM 455kHz filter

SEMICONDUCTORS

Part No.	Symbol & Description
3SK73	Q1
2SK34	Q2
2SK168	Q3, Q15
2SC1906	Q4
2SA535-A	Q5
HA1201	Q6, Q7, Q9
NJM4558DV	Q8
PA3007-A	Q10
PA4006-A	Q11
HA1197	Q12
2SC1919	Q13
2SC2575 (2SC945A)	Q14, Q16-Q21, Q24-Q26
2SA1100 (2SA733A)	Q22, Q23, Q28-Q35
HA12010	Q27
MZ-061 (WZ-061)	D1, D2
1S1555 (1S2473)	D3, D5-D17
1SV69-03	D18

OTHERS

Part No.	Symbol & Description
ASX-130	S1, S2 Remote lever switch (TAPE)
ASK-152	S3, S4 Lever switch (MUTING, LOUDNESS)
AKA-013	Terminal (ANTENNA)
AKB-063	Terminal (TAPE)

Precautions

- The FM ceramic filters (ATF-106, symbol nos. F1 ~ F3) in the tuner assembly (GWE-133) has been selected on the basis of their respective IF offset values (the degree of displacement from the center IF). Filters are graded into 3 ranks, these being identified by color coding at the top (red, orange, and blue). When replacing filters, always use filters of the same color code. When placing orders for these filters, designate the grade (color) as well as the part no.
- The crystal resonator (ASS-012, symbol no. X1) in the detector assembly (GWX-463) is available in 3 different types corresponding to the IF offset values of the FM ceramic filters (ATF-106, symbol nos. F1 ~ F3) in the tuner assembly (GWE-133). These may be identified by the different colored dots (red, blue, orange) at the head. When replacing crystal resonators, check that the color is same as the ceramic filters.

Detector Assembly (GWX-463)

CAPACITORS

Part No.	Symbol & Description
CCDSL 101J 50	C201
CCDWK 150K 50	C202
CKDYB 471K 50	C204
CKDYF 103Z 50	C206

Note: When ordering resistors, convert the resistance value into code form, and then rewrite the part no. as before.

RESISTORS

Part No.	Symbol & Description
RD $\frac{1}{2}$ PM $\square\square\square$ J	R201-R208

SEMICONDUCTORS

Part No.	Symbol & Description
2SC461-B	Q201
2-1K261	D201, D202

OTHERS

Part No.	Symbol & Description
ASS-012*	X1 Crystal resonator
ATE-050	T201 FM detector transformer

Equalizer Assembly (AWM-227)

CAPACITORS

Part No.	Symbol & Description
CCDSL 470K 50	C7, C8
CCDSL 101K 50	C5, C6, C17, C18
CKDYB 471K 50	C19, C20
CQMA 122J 50	C13, C14
CQMA 183J 50	C11, C12
CKDYF 103Z 50	C25
CQMA 683J 50	C15, C16
CEANL 4R7M 50	C3, C4, C23, C24
CEA 470M 50L	C1, C2, C21, C21, C22
CEA 471M 6L	C9, C10
CKDYF 473Z 50	C26

Note: When ordering resistors, convert the resistance value into code form, and then rewrite the part no. as before.

RESISTORS

Part No.	Symbol & Description
RD $\frac{1}{2}$ PM $\square\square\square$ J	R1-R6, R11, R12, R15-R26, R28, R29
RN $\frac{1}{2}$ PQ $\square\square\square$ F	R7-R10, R13, R14
RS2P $\square\square$ J	R27

SEMICONDUCTORS

Part No.	Symbol & Description
HA12017P	Q1, Q2
1S1555	D1, D2

OTHERS

Part No.	Symbol & Description
ASG-231	S1 Push switch (FUNCTION)
AKB-063	Terminal (INPUT)

Tone Control Assembly (GWG-141)

CAPACITORS

Part No.	Symbol & Description
CCDSL 470K 50	C3, C4
CCDSL 101K 50	C5, C6, C9, C10
CKDYB 471K 50	C11, C12
CQMA 332K 50	C23, C24
CQMA 273K 50	C19, C20
CWANL R33M 50	C21, C22
CEANL R22M 50	C15, C16
CEANL 010M 50	C17, C18, C25, C26
CEANL 100M 50	C27, C28, C33, C34
CEANL 4R7M 50	C1, C2
CEA 470M 50L	C29-C32
CEA 470M 25L	C13, C14
CEA 101M 10L	C7, C8

Note: When ordering resistors, convert the resistance value into code form, and then rewrite the part no. as before.

RESISTORS

Part No.	Symbol & Description
RD $\frac{1}{2}$ PM $\square\square\square$ J	R1-R40
ACT-135	VR1 Variable 10k (BASS)
ACT-136	VR2 Variable 10k (TREBLE)

SEMICONDUCTORS

Part No.	Symbol & Description
HA12017P	Q1, Q2

OTHERS

Part No.	Symbol & Description
ASK-152	S1, S2 Lever switch (MODE, LOW FILTER)

Switch Assembly (AWS-146)

Part No.	Symbol & Description
CQMA 332J 50	C1, C2
ASH-015	S1 Slide switch (DE-EMPHASIS)

Switch Assembly (GWS-226)

Part No.	Symbol & Description
ASG-230	S5 Push switch (FM MUTING)

Power Amplifier Assembly (GWH-139)

CAPACITORS

Part No.	Symbol & Description
CQMA 103K 50	C117-C120
CQMA 823K 50	C131, C132
CQMA 332K 250	C113, C114
CCDSL 101K 500	C121-C124
CCDSL 390K 50	C111, C112
CCDSL 470K 50	C105-C110
CCDSL 221K 50	C103, C104
CEANL 4R7M 50L	C101, C102
CEANP R22M 50	C125, C126
CEA 471M 6L	C133
CEA 101M 25L	C134
ACG-009	C127-C130 Ceramic (0.047/150V)

Note: When ordering resistors, convert the resistance value into code form, and then rewrite the part no. as before.

RESISTORS

Part No.	Symbol & Description
RD $\frac{1}{2}$ PM $\square\square\square$ J	R101-R108, R111, R112, R115, R116, R119, R120, R125, R126, R145, R146
RD $\frac{1}{2}$ PM $\square\square\square$ J	R149-R152, R157, R158, R169, R172, R177-R181, R184-R186
Δ RD $\frac{1}{2}$ PMF $\square\square\square$ J	R109, R110, R113, R114, R117, R118, R123, R124, R127-R142, R147, R148
Δ RD $\frac{1}{2}$ PMF $\square\square\square$ J	R153-R156, R159-R164
RD $\frac{1}{2}$ PS $\square\square\square$ J	R143, R144
Δ RD $\frac{1}{2}$ PSF $\square\square\square$ J	R121, R122
RN1H $\square\square\square$ K	R173, R174
RS2P $\square\square\square$ J	R175, R176
Δ ACN-114	R165, R167
TH103-2	Th101, Th102
ACP-062	VR1, VR2 Semi-fixed 330k
ACP-019	VR3, VR4 Semi-fixed 100
ACP-010	VR5, VR6 Semi-fixed 100k

SEMICONDUCTORS

Part No.	Symbol & Description
2SC1775A-E* (2SC1775A-F*)	Q101, Q102
2SA979-F* (2SA979-G*)	Q103, Q104
*hfe of Q101 and Q102 should have the E-rank, if Q103, and Q104 have the F-rank.	
*hfe of Q101 and Q102 should have the F-rank, if Q103 and Q104 have the G-rank.	
2SC2291	Q105, Q106
2SA750 (2SA726S)	Q107, Q108
2SC1915	Q109, Q110
2SA750	Q111, Q112, Q117, Q118

Part No.	Symbol & Description
2SC1400	Q113, Q114, Q119, Q120
2SA905	Q115, Q116
2SA904A	Q121, Q122
2SC1914A	Q123, Q124
Δ 2SC2275-Q* (2SC2275-P*)	Q125, Q126
Δ 2SA985-Q* (2SA985-P*)	Q127, Q128
*hfe of Q125-Q128 should have the same rank.	
2SC2575	Q129-Q133
2SC1384	Q134
MZ-061 (WZ-061)	D101-D106
STV2H	D109, D110
10E2	D111, D112, D117, D118
1S1555 (1S2076)	D113-D116
1S2471	D123-D125, D128
MZ-150 (WZ-150)	D126

OTHERS

Part No.	Symbol & Description
ASR-067 PBZ30P060FMC	RL1 Relay

Power Supply Assembly (GWR-122)

CAPACITORS

Part No.	Symbol & Description
CEA 100M 50L	C206, C227
CEA 470M 50L	C209, C210
CEA 221M 16L	C217
CEA 221P 80	C202, C203
CEA 470M 50L	C207, C208
CEA 471M 16L	C213, C214
CEA 102M 35L	C215
CEA 101M 25L	C216
CEA 470M 10L	C218
CEA 471M 6L	C219
CEA 2R2M 50L	C223
ACG-004	C201, C211, C224 Ceramic(0.01/150V)
CCDSL 101K 50	C204, C205
CKDYF 473Z 50	C220
ACH-212	C225, C226 Electrolytic (12000/56V)

Note: When ordering resistors, convert the resistance value into code form, and then rewrite the part no. as before.

RESISTORS

Part No.	Symbol & Description
RD¼PM □□□ J	R201, R202, R207-R209, R211, R214, R215, R217, R224-R228
△ RD¼PMF □□□ J	R203-R206, R223
RD¼PS □□□ J	R212, R213, R230, R231
RS1P □□□ J	R210, R216

△ RD¼PSF □□□ J	R222
----------------	------

SEMICONDUCTORS

Part No.	Symbol & Description
2SD313	Q201, Q209, Q210
2SK34	Q202, Q206
2SC2575	Q203, Q211
2SC1915	Q204
2SB682 (2SB507)	Q205
2SA912	Q207
2SA905	Q208
△ 10E2	D201-D206
KZL-140	D207
1S1555 (1S2076)	D208, D215
△ 30D4 (SR3AM-4)	D209-D212
MZ-177	D213
MZ-110 (WZ-110)	D214

OTHERS

Part No.	Symbol & Description
ATT-678 PBZ30P060FMC	T1 Heater transformer

Speakers Terminal Assembly (GWS-222)

Part No.	Symbol & Description
△ AKE-054	Terminal (SPEAKERS)
ASX-137	Remote slide switch (SPEAKERS)

Switch Assembly (GWS-223)

Part No.	Symbol & Description
ASX-135	Remote push switch (SPEAKERS)

Headphones Jack Assembly (GWK-146)

Part No.	Symbol & Description
AKN-030 RS2P 331J	Phone jack (PHONES) R1, R2

FL Indicator Assembly (AWV-009)

CAPACITORS

Part No.	Symbol & Description
CEA R47M 50L	C3
CEA 471M 10L	C16, C28
CKDYF 103Z 50	C12, C14, C17-C21, C6
CKDYX 473M 25	C7-C9, C13, C15, C25, C26
CCDCH 101K 50	C22
CCDCH 020C 50	C24
CEANL 010M 50	C1, C2
CEA 101M 25L	C10
CQMA 332J 50	C4, C5
CQSH 201J 50	C23
ACM-010	TC1 Trimmer
CEA 010M 50L	C33-C39
CEA 221M 16L	C31
CCDSL 101K 50	C30, C32
CKDYF 473Z 50	C27, C29

Note: When ordering resistors, convert the resistance value into code form, and then rewrite the part no. as before.

RESISTORS

Part No.	Symbol & Description
RD¼PM □□□ J	R1-R6, R9-R33, R35-R61
ACP-001	VR1, VR2 Semi-fixed 2.2k

SEMICONDUCTORS

Part No.	Symbol & Description
TA7318P-A	Q1
HA12010	Q2, Q3
M54451P	Q4
PD5009	Q5
2SC2575 (2SC945A)	Q6-Q10
2SC461	Q11

OTHERS

Part No.	Symbol & Description
T24-028	L1, L2 RF choke coil
AAV-007	V1 Fluorescent indicator tube (FREQUENCY)
AAV-009	V2 Fluorescent indicator tube (POWER)
ASS-011 VCZ30P080FMC	X1 Crystal resonator

Switch Assembly (GWS-224)

Part No.	Symbol & Description
ASG-230	S3 Push switch (BRIGHTNESS)

11. PACKING

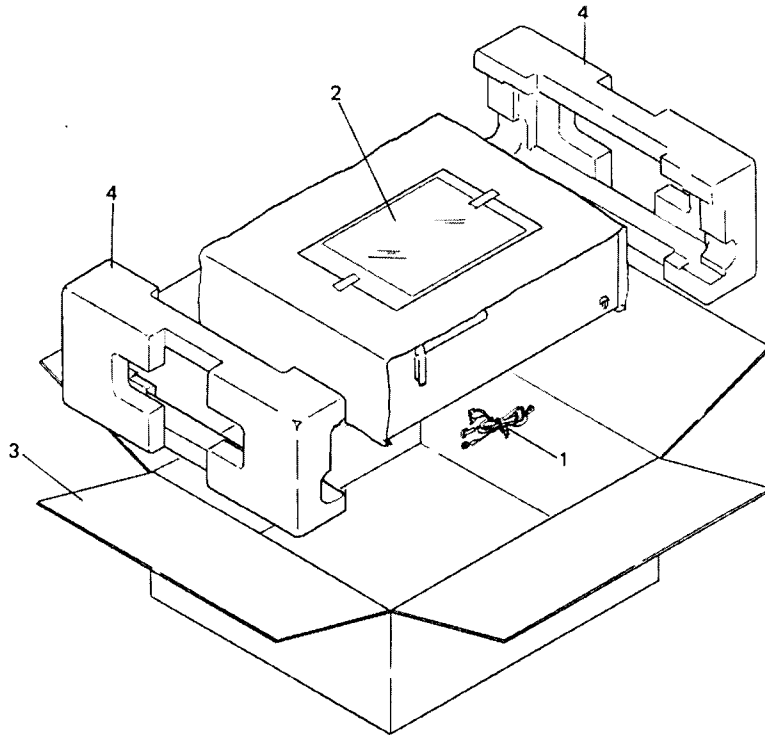

Key No.	Part No.	Description
1.	ADH-002	T-type FM antenna
2.	ARB-355	Operating instructions
3.	AHD-755	Packing case
4.	AHA-246	Side pad

ADDITIONAL

 PIONEER

Service Manual

FM Quartz Locked
STEREO RECEIVER

SX-3800 S/G, S

- The basic performance of the S/G and S types are the same as the KU type. This additional service manual is applicable to the S/G and S types. Please refer to the KU type service manual with exception of this supplements.

1. SPECIFICATIONS

The specifications for S/G and S types are the same as the KU type except for following sections.

Power Requirements

KU type AC 120V, 60Hz
S/G and S types AC 110V, 120V, 220V and 240V,
50/60Hz

Power Consumption

KU type 200W (UL)
S/G and S types 200W

Weight (without package)

KU type 16.2kg (35lb 12oz)
S/G and S types 16.7kg (36lb 13oz)

2. CONTRAST OF MISCELLANEOUS PARTS

NOTES:

- Parts without part number cannot be supplied.
- The Δ mark found on some component parts indicates the importance of the safety factor of the part. Therefore, when replacing, be sure to use parts of identical designation.

ASSEMBLY

Symbol	Description	Part No.		Remarks
		KU type	S/G, S types	
	Switch assembly	AWS-146	AWS-148	DE-EMPHASIS

ELECTRO-PARTS

Symbol	Description	Part No.		Remarks
		KU type	S/G, S types	
Δ T1	Power transformer	ATT-677	ATT-683	
Δ S14	Lever switch (POWER)	ASK-507	ASK-508	
Δ S15	Line voltage selector	AKR-031	
Δ R1	Resistor 2.2M	ACN-029	
Δ	Fuse holder	AKR-032	
Δ	AC power cord	ADG-023	ADG-046	
Δ FU1	Fuse	AEK-109	AEK-109 (S/G) AEK-101 (S)	

PACKING AND FURNISHED PARTS

Symbol	Description	Part No.		Remarks
		KU type	S/G, S types	
	Operating instructions	ARB-355	ARB-357	
	Fuse	AEK-101 (S/G) (AEK-107 (S))	
	Packing case	AHD-755	AHD-758 (S/G) AHD-755 (S)	
	Spacer	AHB-104 (S/G)	

3. SCHEMATIC DIAGRAM, P.C. BOARD PATTERNS AND P.C. BOARD COMPONENT PLACEMENT

3.1 SCHEMATIC DIAGRAM

A

B

C

D

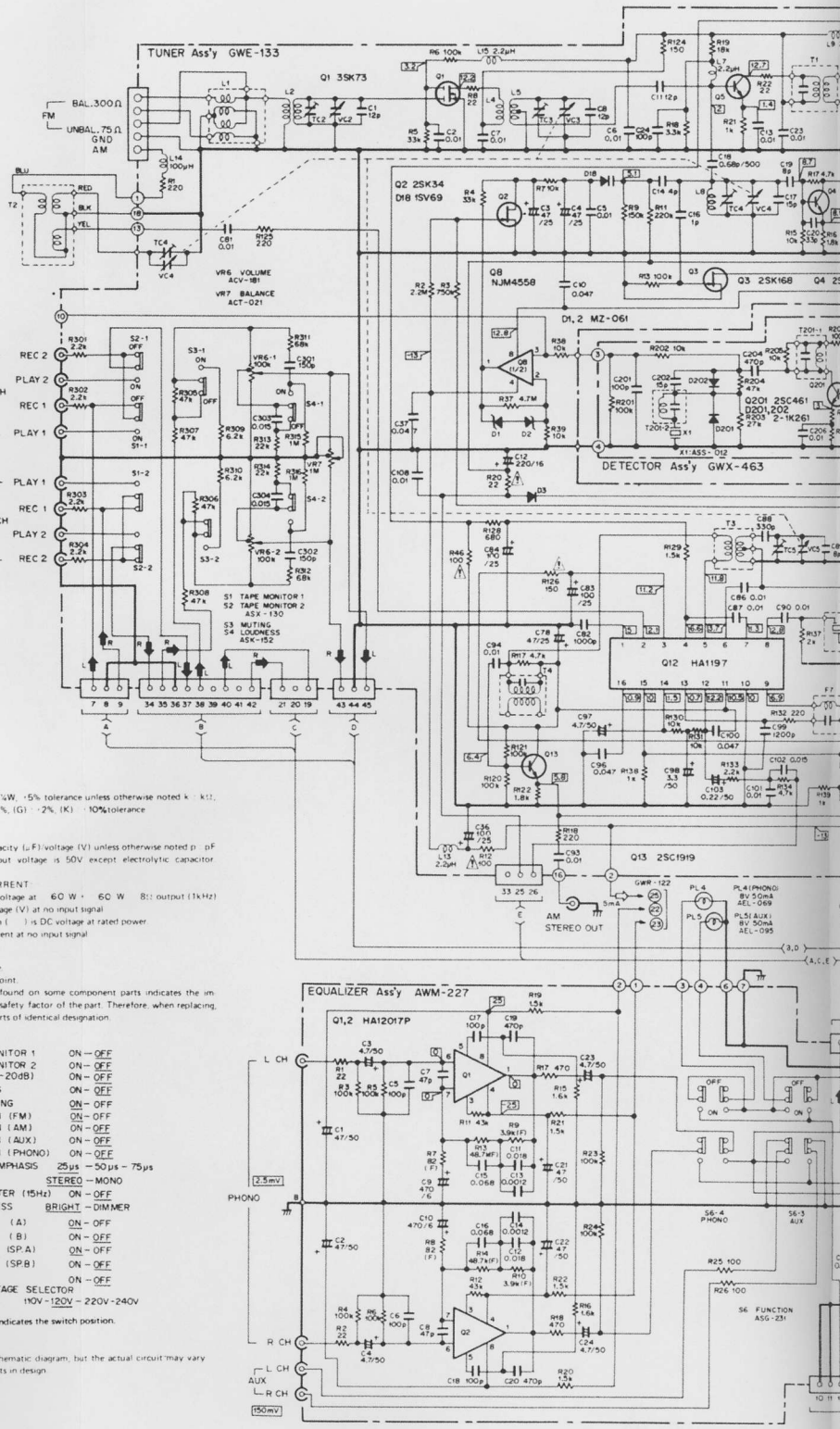

- RESISTORS**
Indicated in Ω, kΩ, M, or G. Tolerance: ±5% unless otherwise noted; ±1% for M, ±2% for K, ±10% for G.
 - CAPACITORS**
Indicated in pF, nF, or μF. Voltage: (V) unless otherwise noted; 50V except electrolytic.
 - VOLTAGE, CURRENT**
 - V: Signal voltage at 60 W, 60 W, 8: output (1k Hz)
 - DC: DC voltage (V) at no input signal
 - Value in | | : 1/4 DC voltage at rated power
 - mA: DC current at no input signal
 - OTHERS**
 - : Signal route
 - ⊗: Adjusting point
 - ⚠: The ⚠ mark found on some component parts indicates the importance of the safety factor of the part. Therefore, when replacing, be sure to use parts of identical designation.
- SWITCHES**
- S1: TAPE MONITOR 1 ON - OFF
 - S2: TAPE MONITOR 2 ON - OFF
 - S3: MUTING (-20dB) ON - OFF
 - S4: LOUDNESS ON - OFF
 - S5: FM MUTING ON - OFF
 - S6-1: FUNCTION (FM) ON - OFF
 - S6-2: FUNCTION (AM) ON - OFF
 - S6-3: FUNCTION (AUX) ON - OFF
 - S6-4: FUNCTION (PHONO) ON - OFF
 - S7: FM DE-EMPHASIS 25 μs - 50 μs - 75 μs
 - S8: MODE STEREO - MONO
 - S9: LOW FILTER (15Hz) ON - OFF
 - S10: BRIGHTNESS BRIGHT - DIMMER
 - S11: SPEAKER (A) ON - OFF
 - S12: SPEAKER (B) ON - OFF
 - S13-1: SPEAKER (SP.A) ON - OFF
 - S13-2: SPEAKER (SP.B) ON - OFF
 - S14: POWER ON - OFF
 - S15: LINE VOLTAGE SELECTOR 110V-120V - 220V-240V
- The underlined indicates the switch position.

This is the basic schematic diagram, but the actual circuit may vary due to improvements in design.

1

2

3

D PARTS LIST

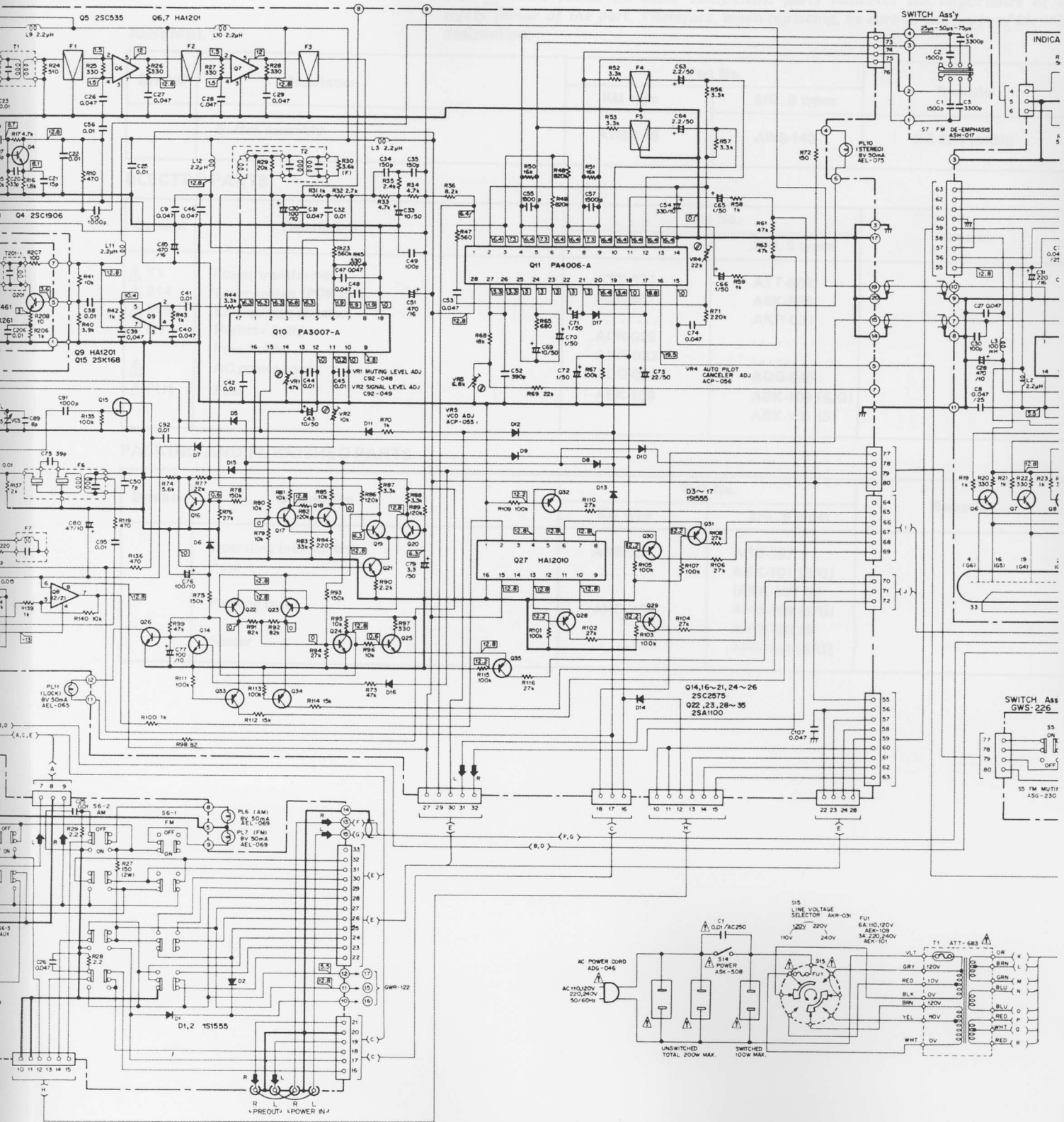

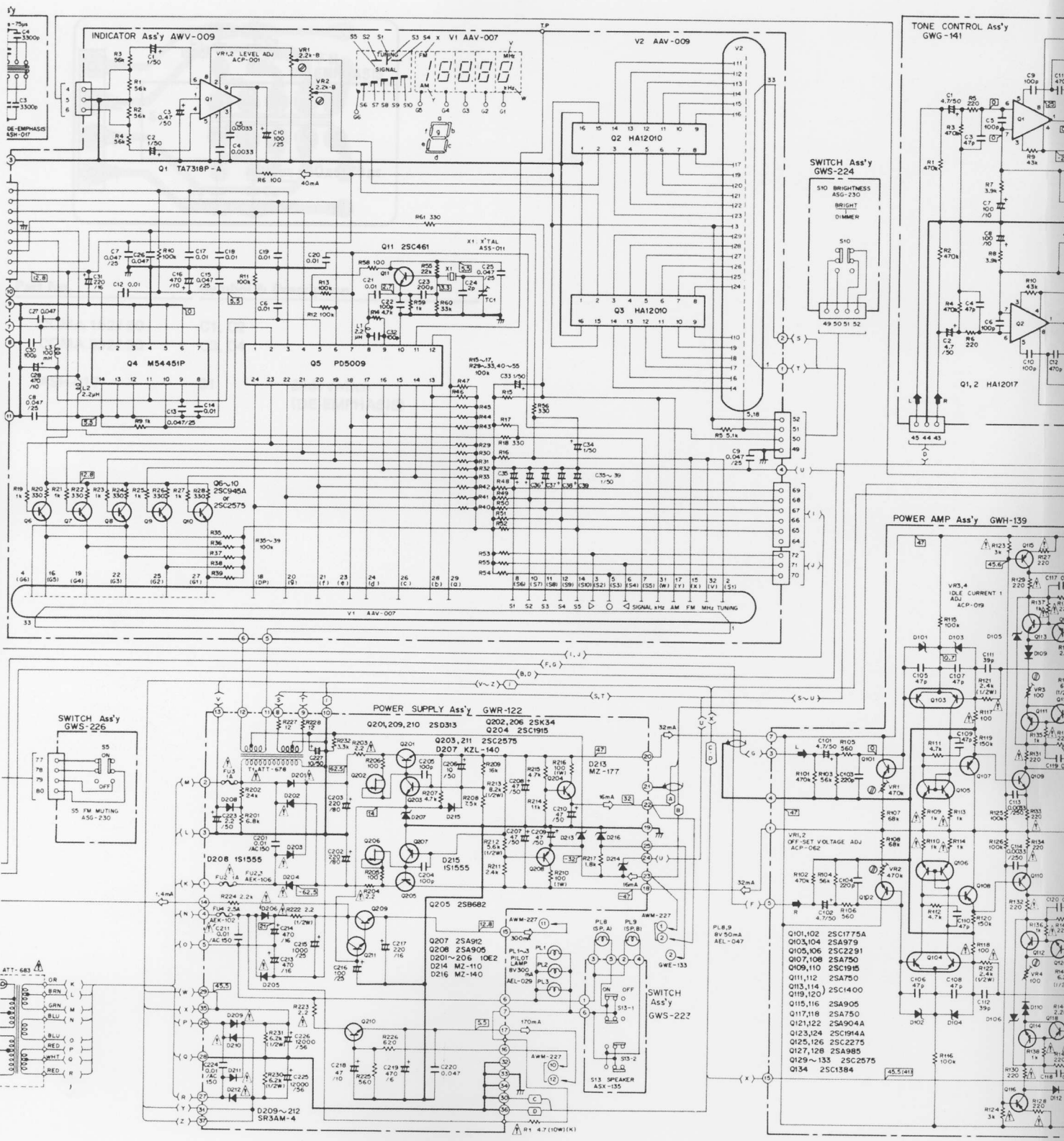

NOTE:
 The indicated semiconductors are representative ones only. Other alternative semiconductors may be used and are listed in the parts list.

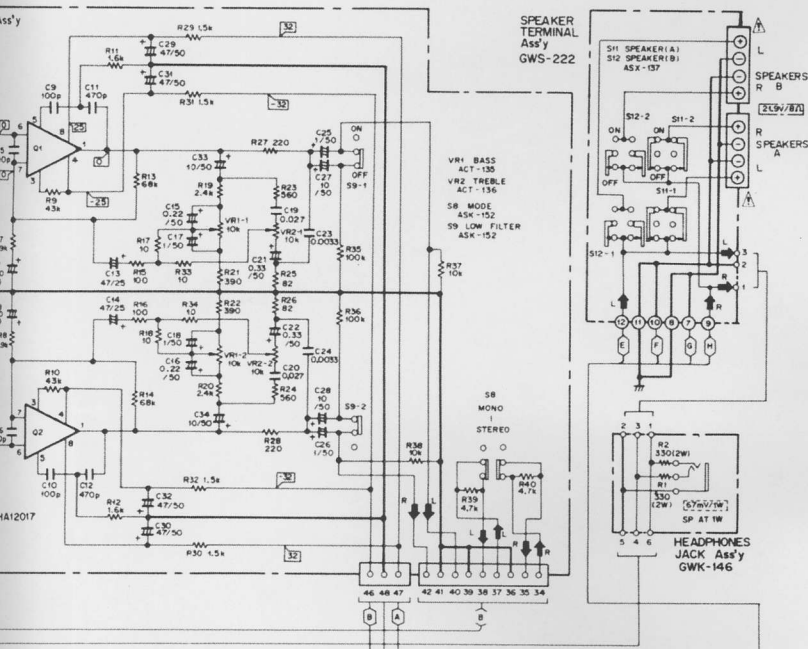

A

B

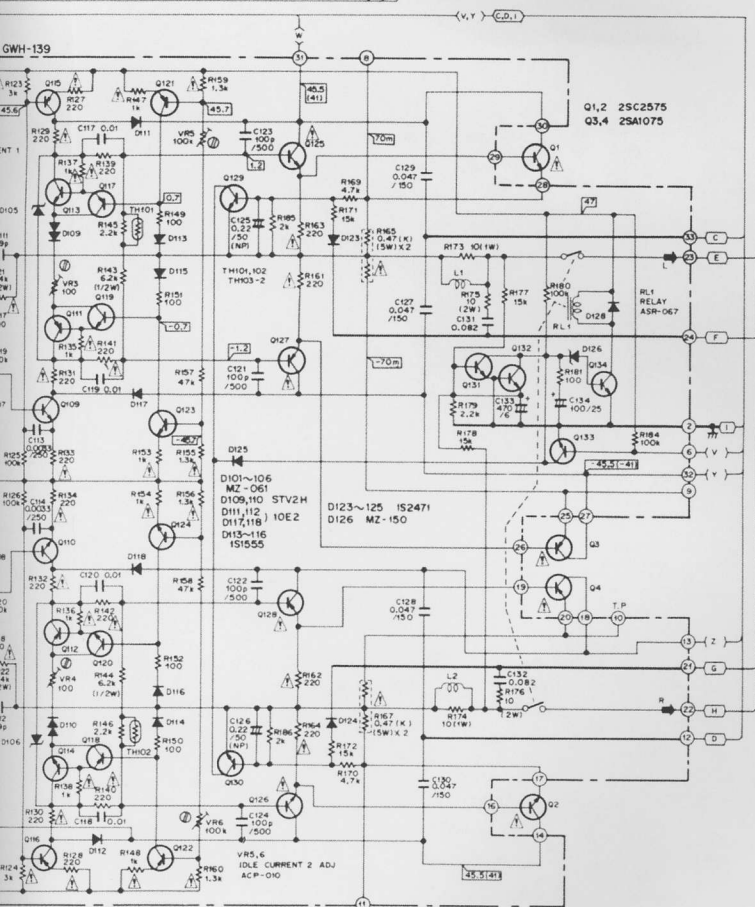

C

D

3.2 SWITCH ASSEMBLY (AWS-148)

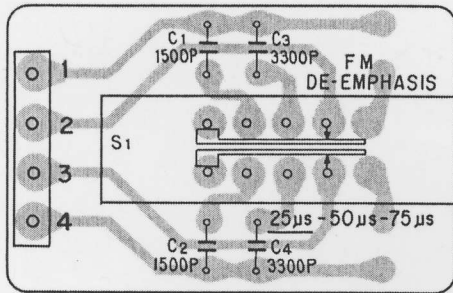

Part No.	Symbol & Description
CQMA 152J 50	C1, C2
CQMA 332J 50	C3, C4
ASH-017	S1 Slide switch (DE-EMPHASIS)